

Auto Sentry® Petro Installation Guide

Version 2.0



Defining the World of Car Wash Technology

Contents

| | |
|--|-----------|
| Chapter 1: Introduction | 4 |
| Purpose | 4 |
| Rules for Installation | 4 |
| Related Documents | 4 |
| Environmental Statement | 5 |
| CE Marking | 5 |
| ETL | 5 |
| Warning Markings | 5 |
| Cleaning | 5 |
| Inspection Information | 5 |
| Training and Support | 5 |
| Wiring Colour Codes | 5 |
| | |
| Chapter 2: Site Planning | 2 |
| Location | 2 |
| Dimensions, Measurements, and Ratings Specifications | 2 |
| Auto Sentry Petro Power Requirements | 2 |
| Cable Sizing | 3 |
| Auto Sentry Petro Wiring Guidelines | 3 |
| Cable Plan Guidelines | 3 |
| Earthing | 4 |
| In-bay Layout | 4 |
| Placement of the Auto Sentry Petro | 5 |
| Dimensions of the Auto Sentry Petro | 6 |
| Base Placement with a Riser | 7 |
| Base Placement without a Riser | 8 |
| Door Swing Clearance | 9 |
| Riser Dimensions | 9 |
| | |
| Chapter 3: Molded Plastic Installation | 10 |
| Hardware for Roto Molded and Plastic Installation | 11 |
| Plastic and Roto Mold Parts Identification | 11 |
| Plastic and Roto Molded Installation | 12 |
| Roto Molds to Cover Metal Base Installation | 12 |

Chapter 4: System Wiring17

AC Power Terminations 17

Power Wiring Plan 18

Control Box Terminations 19

In-Bay Controller Wire Terminations 20

In-Bay Wiring Layouts 21

Communications Wiring 22

System Network Cables 23

Chapter 5: Parts Identification24

Exterior Components (Front View) 24

Plastic and Roto Mold Parts 25

Power Terminal Blocks 25

Interior Front Door Components 26

Interior Rear Left-Side of Auto Sentry Petro 27

Interior of Rear Door Components 28

Interior Rear Right-side 29

Chapter 1: Introduction

This document was written for installation technicians and electricians. A thorough understanding of electrical wiring, installation, local regulations, and safety protocols is required. No prior experience with the Auto Sentry Petro is required.

Purpose

This guide is provided to assist you during installation of the Auto Sentry Petro. To ensure proper installation, this guide should be supplied to the electrician prior to the installation of cable and wiring.

WARNING: Faulty installations are the major cause of system malfunctions. The Auto Sentry Petro system must be installed exactly as described in this manual to ensure its reliability and proper operation.

Many of the features you will find in the Auto Sentry Petro system were integrated at the request of current car wash operators. We welcome your feedback and want to assure you that PSD Codax will always remain the best in the industry in car wash controller and management systems.

By reading the information and performing the procedures in this manual you should be able to:

- Install the Auto Sentry Petro system level wiring
- Install the Auto Sentry Petro communications wiring
- Troubleshoot problems if they occur

Rules for Installation

Before you begin, please read this entire manual.

WARNING: Imminent danger exists of electrical shock if the terminal is not installed by a certified electrical contractor.

- ALL wiring must meet local standards for electrical installation regulations.
- Cables can be contained in rigid PVC conduit or metal conduit.
- High-voltage (AC) and low-voltage (DC) must not be combined in a common conduit, junction box, or wire trough.
- Power for the Auto Sentry Petro and any peripherals must come from the dedicated UPS, as supplied by PSD Codax.
- The heat exchanger power is not conditioned.
- The Auto Sentry Petro and peripheral equipment must be properly earthed. See Earthing for more information.
- Examine all boxes and cartons before disposing of them for manuals, cables, connectors, and other miscellaneous parts.

Related Documents

The Auto Sentry Petro User Manual is available for further reference.

Environmental Statement

PSD strives to create top quality products that minimise the impact on the environment. We work with all our partners to produce products that are in compliance with the relevant environmental regulations and legislation.



We also recognize our responsibility to minimise the quantity of electrical and electronic waste reaching landfill. For this reason, we encourage reuse or responsible disposal of waste electronic and electrical equipment (WEEE). All applicable products are marked with the crossed out wheelie bin label to indicate the need for responsible disposal.

CE Marking



The WashConnect® is CE Certified. CE is a certification mark that indicates the conformity with health, safety, and environmental protection standards for products sold within the European Economic Area.

ETL



The Auto Sentry Petro is listed in Intertek's Directory of Listed Products.

Conforms to

UL STD 62368-1

UL STD 60950-22

Certified to CSA

STD C22.2 62368-1

STD C22.2 60950-22

Warning Markings



This warning symbol (found on equipment and hardware) indicates you should consult accompanying documentation before proceeding.

Consult accompanying documentation before proceeding.

Cleaning

Wipe exterior of unit with damp cloth to clean. Do not use chemicals or cleaning agents.

Inspection Information

Preventative maintenance involves an inspection of the Auto Sentry Petro unit daily for loose connections or damage by untrained or skilled operator.

Training and Support

Contact PSD Codax for additional training and support.

Wiring Colour Codes

The following table displays the harmonised core cable colours for electrical installation.

| Alpha Code | Wire Type | Wire Colour |
|------------|-----------|--------------|
| L | Live | Brown |
| N | Neutral | Blue |
| E | Earth | Green/Yellow |

Chapter 2: Site Planning

Careful planning for the layout of the site will help eliminate possible problems with the start-up of your system and will ensure continued, reliable system operation.

Location

- The Auto Sentry Petro has been designed to operate in an outdoor environment.
- The unit itself contains two hinged-panel doors, one on the front and one on the back of the unit. The Auto Sentry Petro must be located with enough clearance for the doors to open easily without obstructions.
- The unit must be located so that conduit connections can be easily made and the internal components can be accessed.

Dimensions, Measurements, and Ratings Specifications

When mounting the unit, minimum clearances must meet local recommended standards.

| Dimension | Amount | Notes |
|-----------------------------|------------------|---|
| Width | 82.5 cm | — |
| Height | 140.9 cm | — |
| Depth | 43.2 cm | Includes heat exchanger cover panel. |
| Weight | 113.4 kg | — |
| Operating Temperature Range | -29 °C to 60 °C | — |
| Frequency | 50/60 Hz | — |
| Supply Voltage | 240 VAC | Intended for permanently connected supply. |
| Max. Amp. | 5 Amps @ 240 VAC | — |
| IP Rating | IP66 | Enclosures constructed for either indoor or outdoor to provide a degree of protection against falling dirt, rain, sleet, snow, windblown dust, splashing water, and hose directed water that will be undamaged by the external formation of ice on the enclosure. Including protection against corrosion. |

Auto Sentry Petro Power Requirements

- Electrician to provide a dedicated 240VAC, 10A circuit to the Auto Sentry Petro.
- The unit must be properly earthed. See "Earthing" on page 4 for more information.
- When mounting the unit, minimum clearances must meet local regulations.

Cable Sizing

Each installation will vary depending on what type of cable is used, the load (Amps), how long is the cable run, what type of building construction, the environment, and how many other cables are installed. Therefore, cable sizing would be decided and calculated to be site and installation specific. To determine cable size needed, the electrical contractor will refer to the electrical regulations book and make a decision for the best installation.

Auto Sentry Petro Wiring Guidelines

- Run conduit and wires up through the center of the stainless-steel base into the unit.
- For an existing site, use a hole saw to drill new conduit holes through stainless steel base if necessary. File and tape edges of new holes before affixing conduit.
- Use wiring ties and wire clamps inside unit to contain wires.
- All conduit runs should meet local and national codes. Conduits shall be properly connected and securely fastened to the boxes with listed conduit hubs, and should be tightened to the torque specs of the manufacturer.

Cable Plan Guidelines

- All conduit must be rigid PVC or metal.
- All conduit runs should meet local regulations. Conduits shall be properly connected and securely fastened to the boxes with listed conduit hubs, and should be tightened to the torque specs of the manufacturer.
- High-voltage (AC) and low-voltage (DC) must not be combined in a common conduit, junction box, or wire trough.
- Use wiring ties and wire clamps inside unit to contain wires.

Earthing

The Auto Sentry Petro and peripheral equipment must be properly earthed.

Earthing to Local Regulations



Proper earthing is an extremely important part of the system installation. Earthing for all system devices should be wired to the breaker panel earth clamp bar which, in turn, should be earthed to an earthing rod. It is recommended that the neutral and earth clamp bars be bonded together when it is not prohibited by local regulations.

The universal earthing symbol identifies the earthing terminal located in the upper left chamber, bottom left side near terminal blocks. A second earthing terminal is marked and located in the base, bottom left. This is the dedicated 240 V line for the heat exchanger.

WARNING: Earth wire must be connected to the earth terminals. Failure to properly earth the unit could result in unit failure and/or bodily injury.

IMPORTANT: Improper earthing will void equipment warranty.

In-bay Layout

NOTE: ICS DOES NOT RECOMMEND AN IDEAL DISTANCE BETWEEN THE AUTO SENTRY PETRO AND THE ENTRANCE TO THE IN-BAY TUNNEL, BUT DOES OFFER THE FOLLOWING INFORMATION TO THE IN-BAY OWNER FOR THEM TO DECIDE WHAT THE APPROPRIATE DISTANCE SHOULD BE FOR THEIR SITE:

- 1. THE TYPE OF IN-BAY AUTOMATIC:** EACH IN-BAY AUTOMATIC IS DIFFERENT AND THEY ALL EXPEL DIFFERENT AMOUNTS OF BOTH WATER AND CHEMICALS, WHICH IF BLOWN ONTO THE AUTO SENTRY PETRO IN ANY GREAT AMOUNT COULD IMPEDE THE USERS ABILITY TO SEE AND/OR PROPERLY UTILISE THE TOUCH SCREEN.
- 2. THE RELATIVE WIND DIRECTION:** IF THE PREVAILING WIND BLOWS FROM THE AUTO SENTRY PETRO TO THE BAY ENTRANCE, THEN THERE SHOULD BE ONLY MINOR PROBLEMS FROM BLOW-BACK. IF THE PREVAILING WIND BLOWS THROUGH THE BAY TOWARDS THE AUTO SENTRY PETRO THEN THE AUTO SENTRY PETRO WILL BE GREATLY AFFECTED. IF THE PREVAILING WIND IS PERPENDICULAR TO THE TUNNEL THERE WILL AGAIN BE MINOR PROBLEMS.
- 3. DRYER TYPE:** THE TYPE OF DRYER USED IN THE WASH WILL ALSO BE A FACTOR. DRYERS THAT SIMPLY BLOW DOWN THE TUNNEL TOWARDS THE AUTO SENTRY PETRO WILL FACILITATE THE BUILDUP OF WATER AND CHEMICALS ON THE AUTO SENTRY PETRO EVEN ON WINDLESS DAYS.
- 4. BAY DOORS:** IF BAY DOORS ARE INSTALLED AND CLOSE BETWEEN VEHICLES, THEN THERE SHOULD NOT BE ANY PROBLEMS AT ALL AND THE AUTO SENTRY PETRO CAN BE PLACED AS CLOSE TO THE ENTRANCE AS POSSIBLE WHILE ALLOWING A SECOND VEHICLE TO PULL UP TO THE AUTO SENTRY PETRO WITH ENOUGH ROOM FOR THE CUSTOMER TO OPERATE IT WHILE THE FIRST CAR IS IN THE TUNNEL (MINIMALLY THIS DISTANCE IS 3700mm FROM THE CENTER OF THE AUTO SENTRY PETRO TO THE NEAREST OBSTRUCTION).

ALL OF THE ABOVE FACTORS MUST BE TAKEN INTO CONSIDERATION WHEN DETERMINING THE BEST LOCATION FOR THE AUTO SENTRY PETRO IN RELATION TO THE ENTRANCE OF THE WASH BAY. AS A GENERAL RULE, THE FURTHER AWAY THE AUTO SENTRY PETRO IS FROM THE BAY ENTRANCE, THE BETTER OFF IT WILL BE.

*** THIS DRAWING IS ONLY INTENDED TO SHOW THE GENERAL LAYOUT AND DIMENSIONS NECESSARY FOR THE PROPER PLACEMENT OF THE AUTO SENTRY PETRO. ANY DEVIATION MAY CAUSE DAMAGE TO THE AUTO SENTRY PETRO. THIS DRAWING IS NOT TO SCALE. ***

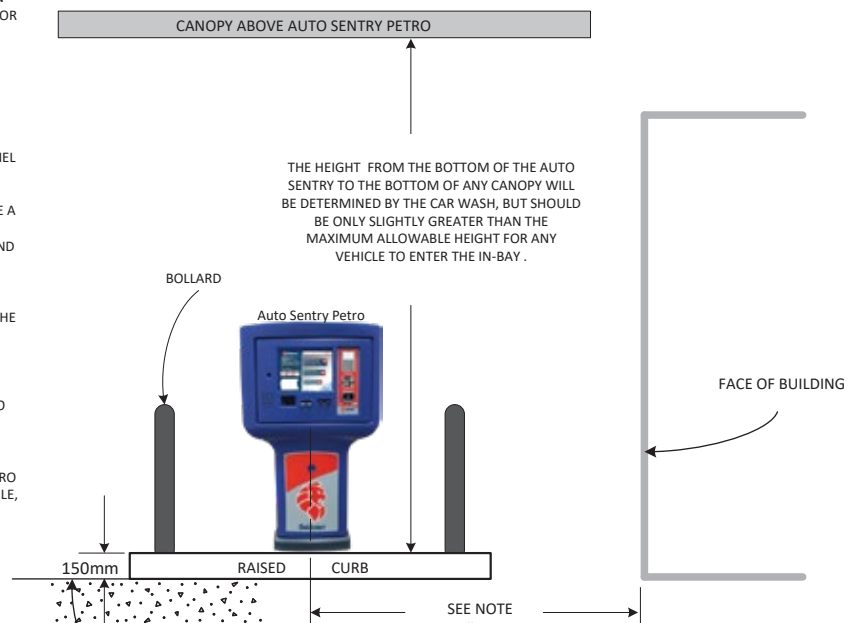

Figure 1. In-bay Layout

Placement of the Auto Sentry Petro

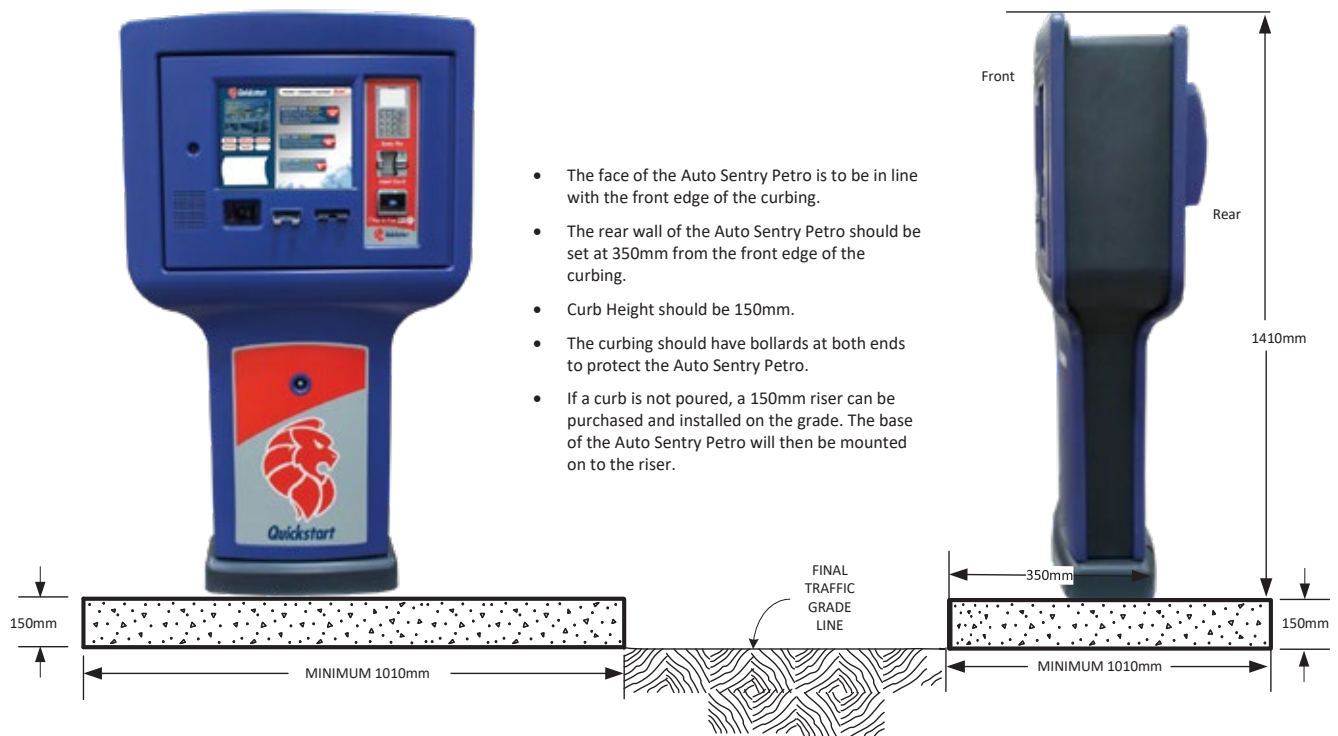

Figure 2. Placement of the Auto Sentry Petro

Dimensions of the Auto Sentry Petro



The Auto Sentry Petro is the primary point-of-sale for the car wash. It is installed outside near the entrance of the car wash with a canopy placed over it.

Figure 3. Dimensions of the Auto Sentry Petro

Base Placement with a Riser

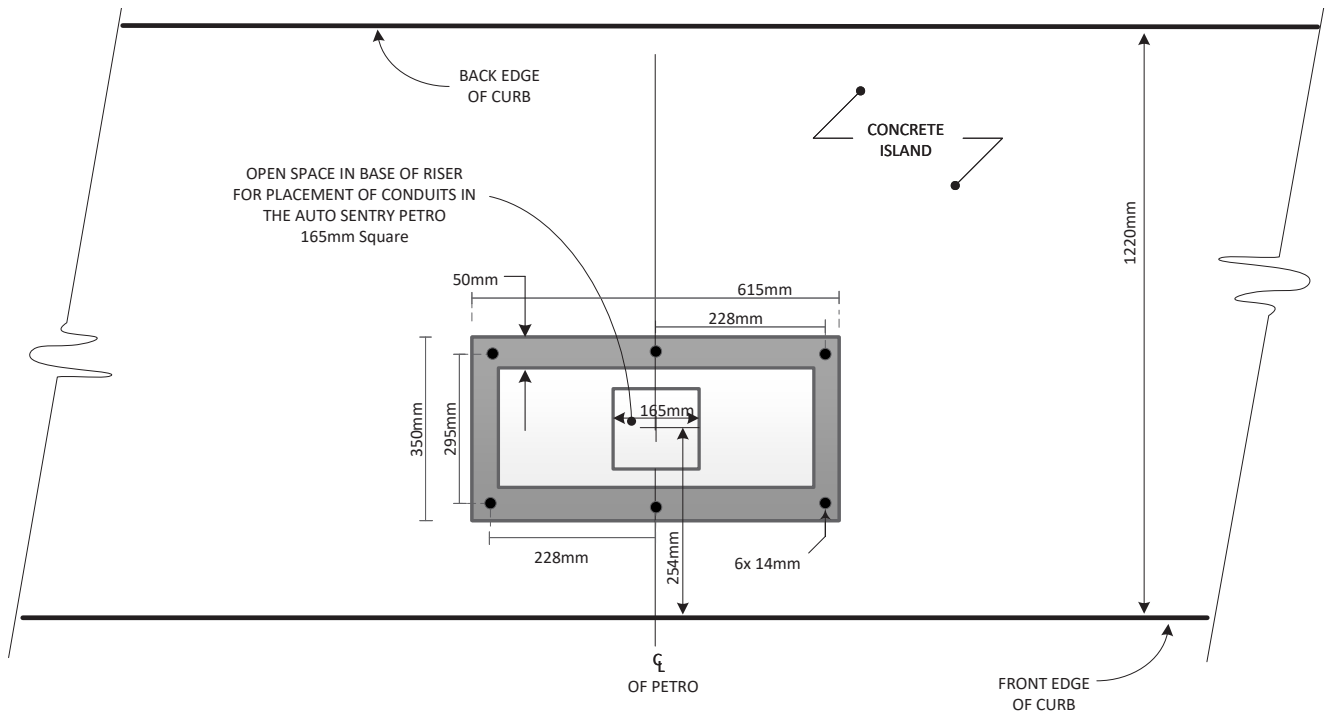

Figure 4. Base Placement with a Riser

Base Placement without a Riser

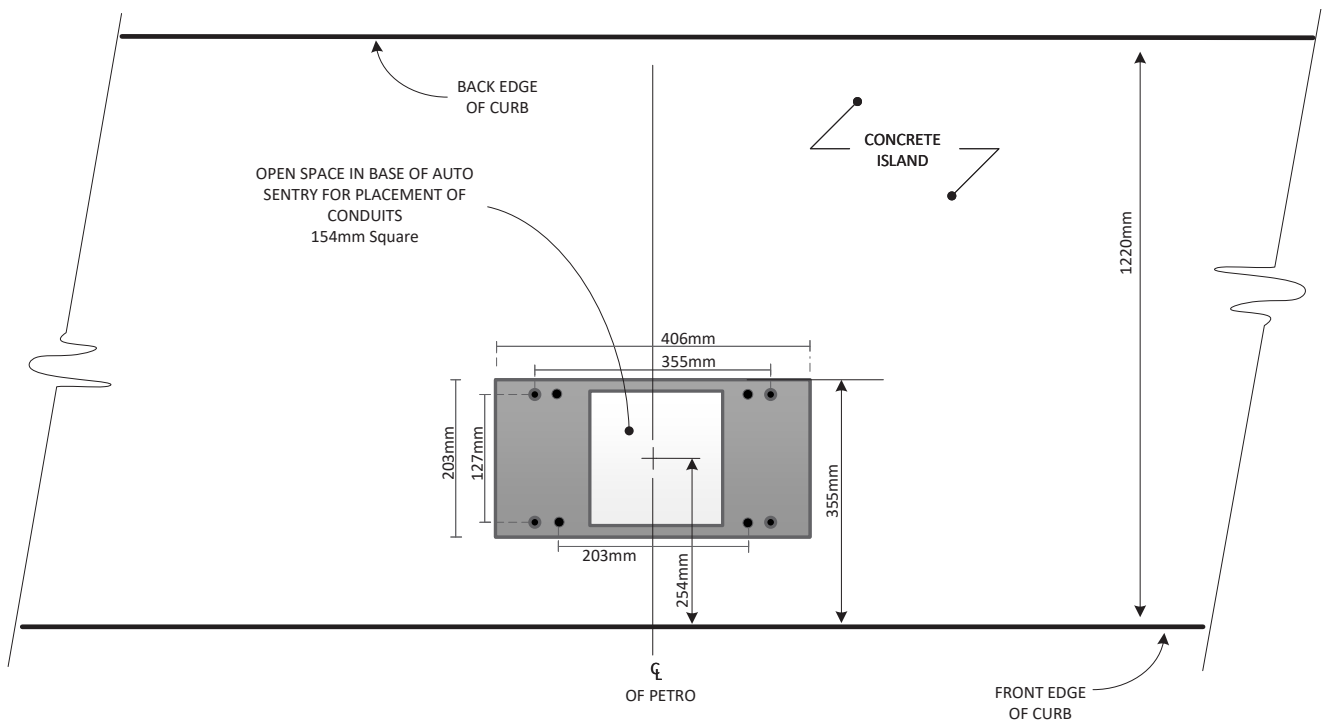

Figure 5. Base Placement without a Riser

Door Swing Clearance

AUTO SENTRY PETRO DOOR SWING CLEARANCE Top View

Drawing is not to scale.

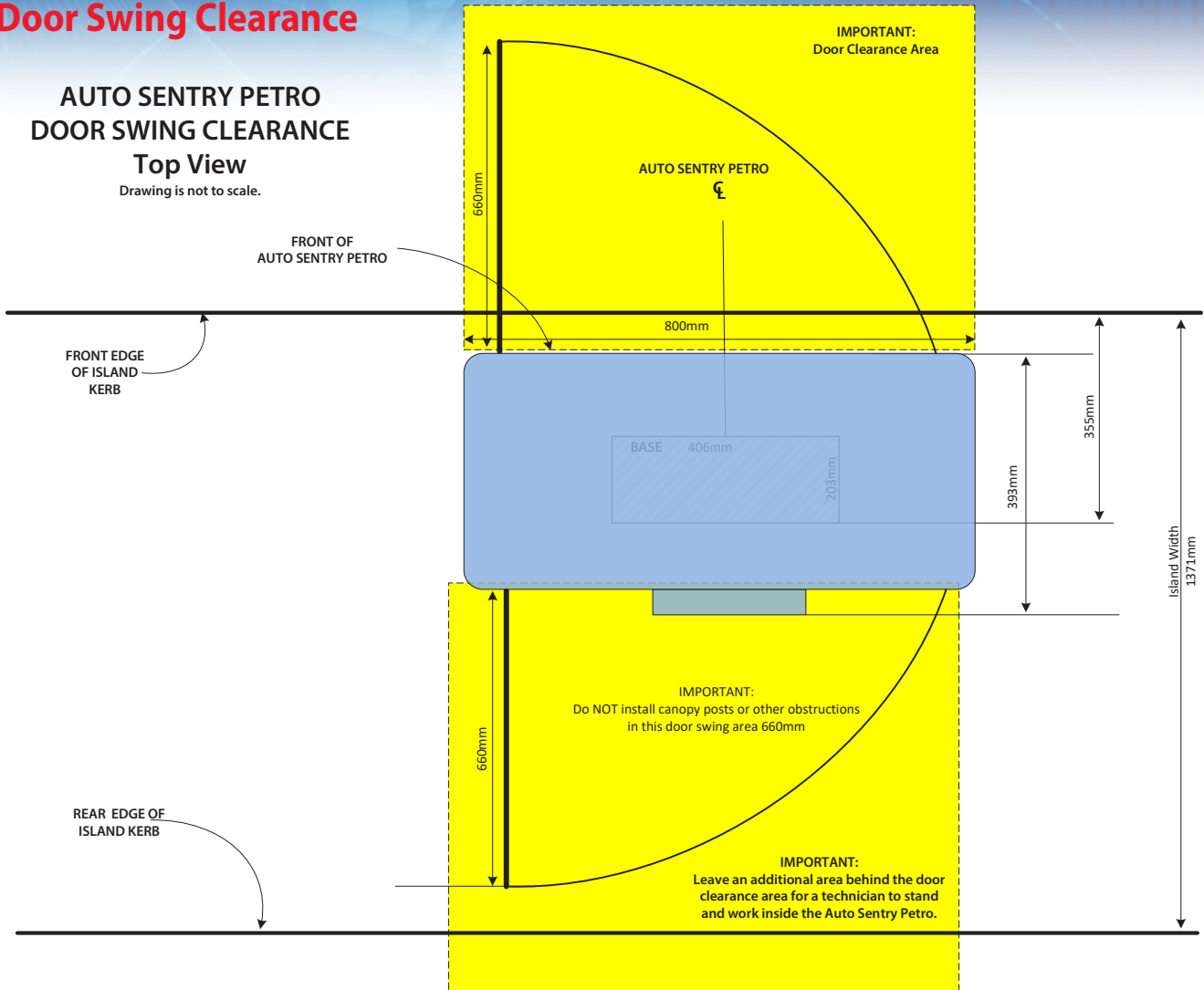

Figure 6. Door Swing Clearance

Riser Dimensions

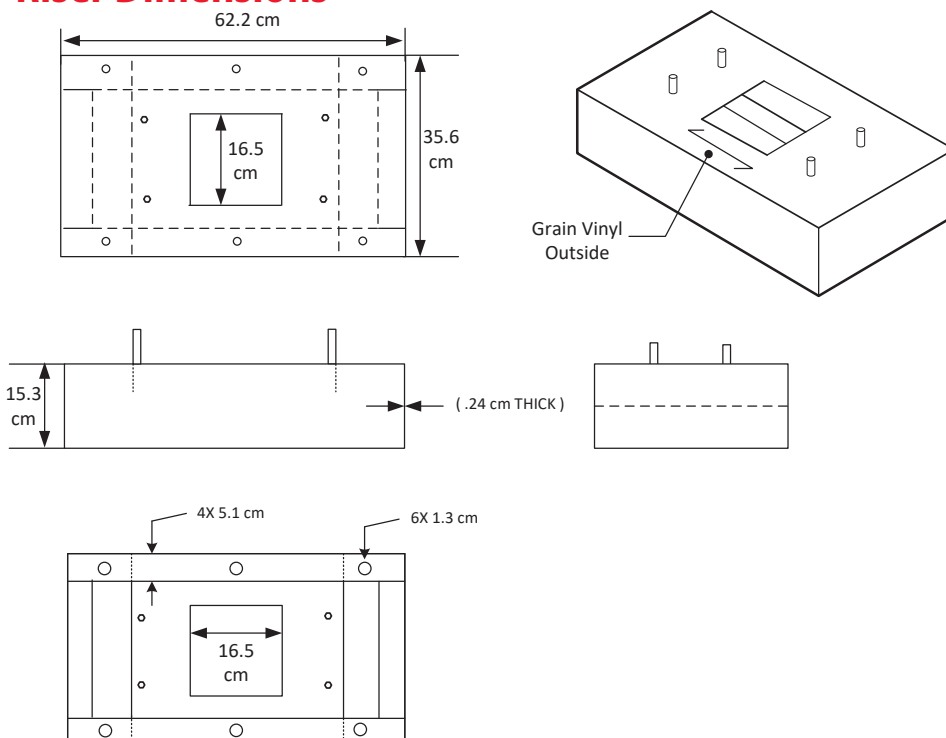

Figure 7. Riser Dimensions

Chapter 3: Molded Plastic Installation

The Auto Sentry Petro is designed to be rugged from the inside out. The heart of this design is a solid stainless steel metal cabinet with full air conditioning. The durable roto molded plastic surrounds and protects the metal cabinet core and gives the Auto Sentry Petro a fresh new style. Brand vinyl with your logo and graphics to make the Auto Sentry Petro your own.

After the J bolts have been set in the concrete according to your site plan, the installation of your Auto Sentry Petro can begin.

Attaching the Auto Sentry® Petro to the J Bolts in the Concrete

***IMPORTANT:** If your site does not have a raised kerb, contact ICS to order a 150mm metal riser. The riser is required to give the proper height necessary to deliver to your customers, the most optimal ergonomic experience at the Auto Sentry Petro.

Items Needed: nuts and washers (site provided) for the 10mm J bolts to attach the base.

1. Lift up the base of the Auto Sentry Petro and place over the J bolts.

PETRO BASE PLACEMENT J Bolts



NOTE: If installing the Auto Sentry Petro directly on the concrete kerbing, the first four J bolts are standard. If available, the extra four J bolts simply provide added security but are not necessary.

Figure 8. J bolts Placement for Base

2. Run the power cable and two Cat 6 cables (the 2nd Cat 6 is for EMV only) to the Auto Sentry Petro and pull them up through the center of the Auto Sentry Petro's pedestal.
3. As you line up the J bolts to the holes in the base of the Auto Sentry Petro, place the Auto Sentry® Petro on top of the concrete.
4. Tighten (4) or (8) nuts and (4) or (8) washers to the J bolts.

NOTE: If you are attaching (4) J bolts in your concrete, attach #1-4 in Figure 6. If you have (8) J bolts in your concrete, then attach #1-8 in the figure above. Using (8) J bolts is optional.

Hardware for Roto Molded and Plastic Installation

NOTE: After the Auto Sentry Petro is secured to the concrete with the J bolts, the next step is to attach the five Roto Molded Plastic pieces to the metal core of the Auto Sentry Petro using the following plastic bags of hardware:

| Hardware Bag | Contents |
|----------------------|--|
| Bag A | (6) ¼" - 20 × 1½" cap screws and Bag H (6) ¼" washers |
| Bag B | (4) ¼" - 20 × 1½" oval screws |
| Bag C | (3) #10 - 1½" screws with (3) #8 washers |
| Bag D & I | (21) #8 - 11 × 1 ¼" screws with (21) #8 flat washers |
| Bag E | (8) ¼" - 20 × ¾" bolts |
| Bag F | (8) #10 - 32 × ½" machine screws (no washers) |
| Bag J | (8) #10 - 32 × 1" screws (no washers) |
| Bag K | (19) # Keps |
| Bag M | (1) #6 - 32 × ¾" Machine Screws |
| Bag N | (20) Rubber Washer |

Plastic and Roto Mold Parts Identification

NOTE: The front and rear covers and doors are available in either blue or gray.

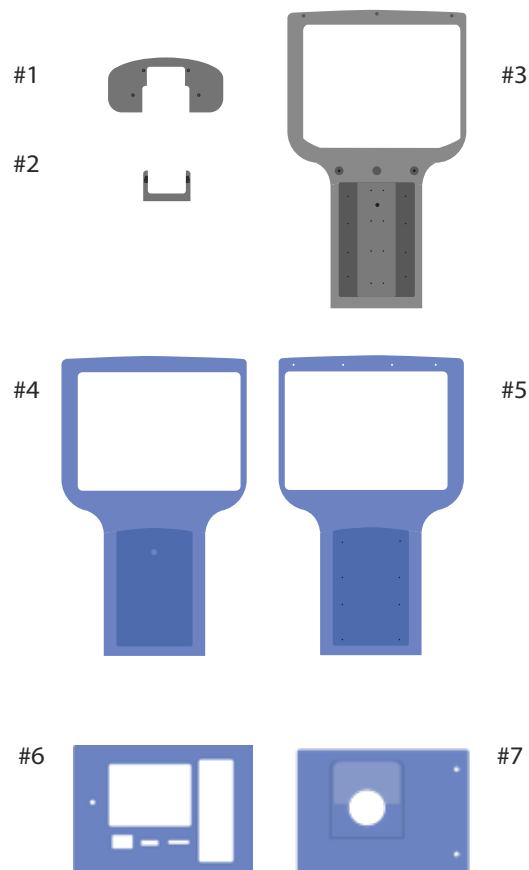

| # | ICS Part Number | Description |
|---|---------------------------|--|
| 1 | AS4PLAS3 | Foot Step Roto Mold for AS4ENC |
| 2 | AS4PLAS2 | Foot Insert Roto Mold for AS4ENC |
| 3 | AS4PLAS1 | Center Plastic for AS4ENC |
| 4 | AS4PLASTF AS4PLASTFCG | Front Plastic Cover Blue Front Plastic Cover Gray |
| 5 | AS4PLASTR AS4PLASTRCG | Rear Plastic Cover Blue Rear Plastic Cover Gray |
| 6 | AS4PLASTB AS4PLASTFDG | Front Plastic Door Blue Front Plastic Door Gray |
| 7 | AS4PLASTRD AS4PLASTRDG | Rear Plastic Door Blue Rear Plastic Door Gray |

Figure 9. Roto Molded Plastic Parts

Plastic and Roto Molded Installation

1. Locate the plastic front door #6 in Figure 9.
2. Place the rubber washers (bag N) on the plastic front door's mounting studs.
3. Carefully align the plastic front door to the metal face housing, insuring all rubber washers stay in place, and then secure with Keps nuts (bag K). DO NOT over tighten.
4. Locate plastic rear door #7 in Figure 9.
5. Place the rubber washers (bag N) on the plastic rear door's mounting studs.
6. Carefully align the plastic rear door to the metal face housing, insuring all rubber washers stay in place, and then secure with Keps nuts (bag K). DO NOT over tighten.

Roto Molds to Cover Metal Base Installation



Figure 10. Holes in Metal Base used to Secure Roto Molded parts

1. Locate #1 and #2 small gray roto molded parts shown in Figure 9.
2. Place roto mold #1 on the front of the base and place roto mold #2 on the rear of the base. These two parts fit together to cover the base of the metal pedestal. See Figure 11.
3. Line up the holes in the roto molded cover with the holes in the Metal base. See Figure 10



Figure 11. Base Roto Molded Parts and Hardware Bag A & H

4. Insert (2) 1/4" - 20 x 1 1/2" cap screws with 1/4" flat washers. (Bag A / Bag H)
5. Use a 3/16" hex key tool to tighten the screws snugly and attach roto mold #1 and #2.

DO NOT OVER TIGHTEN. Two pound-foot torque is recommended. Over torquing could cause shearing or cracking.

6. Locate the gray full-size Auto Sentry Petro roto mold #3. See Figure 9.

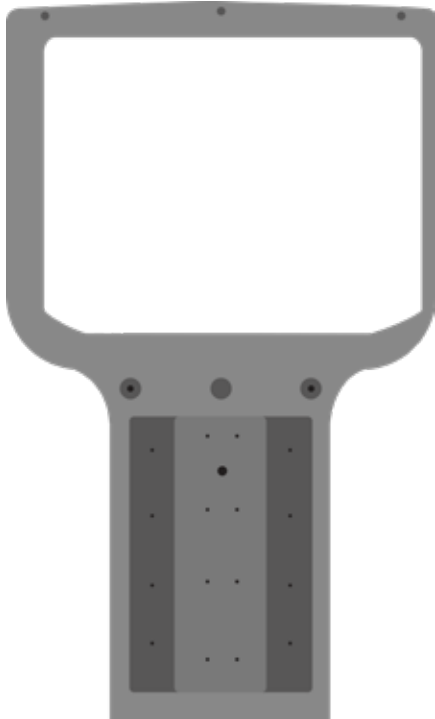

Figure 12. Center Plastic (#3 in Figure 8)

7. On the Auto Sentry Petro, open the front door to perform the next step.
8. Remove the plastic keeper on the sonic sensor. You will need to put this back on after the plastics are completely installed.
9. Place the Roto Molded Plastic (#3 in Figure 9) over the Auto Sentry Petro metal core.
10. Use a #2 Phillips screwdriver and install (4) $1/4" \times 20 \times 1 1/2"$ oval screws (Bag B). There are ten holes but you only need to use four of the ten, preferably below the sonic sensor. See Figure 11.



Figure 13. Specified holes on the front plastic part and hardware Bag B

11. On the back of the Auto Sentry Petro, line up the three metal tabs at the top to the holes in the gray roto mold #3. See Figure 14.



Figure 14. Metal tabs on the rear of the Auto Sentry Petro

12. Install (3) of the #8 -11 x 1 ¼" and (3) of the #8 Flat Washers from (Bag D & I) across the top gray on the back of the Auto Sentry Petro. See Figure 12.
13. Open front door of the Auto Sentry Petro.
14. Locate the blue/gray plastic #4 and then place it on the front of the gray Center Plastic #3. See Figure 15.

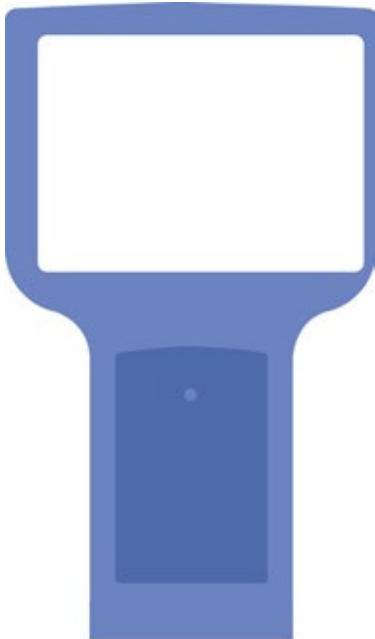

Figure 15. Front Plastic Cover #4 (Blue/Gray)

15. At the top of the Auto Sentry Petro where the blue or gray plastic meets the gray plastic, you can line up the screw holes. See Figure 16.

NOTE: The (4) silver screw holes across the top of roto mold #3 are for optional sign attachment. Contact ICS Marketing for custom toppers (additional fees apply).



Figure 16. Attach Blue Roto Mold #4 with (3) screws to gray Roto Mold #3

16. Install and tighten (3) #10 x 1 1/2" screws with #8 flat washers (Bag C) across the top where the blue or gray plastic meets the gray plastic. See Figure 14.

17. In the holes that are set deep inside the back of the Auto Sentry Petro pedestal, secure (8) #10 - 32 x 1" screws with #8 washers (Bag J). See Figure 17.

DO NOT OVER TIGHTEN. 6.5Nm torque is recommended. Over torquing could cause shearing or cracking.



Figure 17. Tighten (8) screws in the rear of the Auto Sentry Petro

18. Attach the metal mounting plate with the ribs facing out to the back of the Auto Sentry Petro pedestal with (8) 1/4" x 20 x 3/8" bolts (Bag E). See Figure 17.

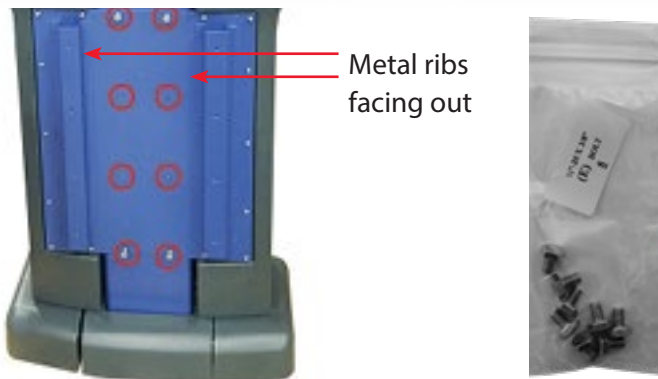

Figure 18. Attach Metal Mounting Plate with Ribs Facing Out and Hardware Bag E

19. Install and tighten (14) #8 x 11 x 1- 1/4" screws and flat washers (Bag D & I) around the perimeter of the metal mounting plate. See Figure 19.



Figure 19. Tighten 14 Screws and Hardware Bag D & I

20. Place the blue roto mold #5 on the back of the Auto Sentry Petro.

DO NOT OVERTIGHTEN for steps #20 and #21. 6.5Nm torque is recommended. Over torquing could cause shearing or cracking.



Figure 20. Rear Plastic Cover (#5 from Figure 8)

21. Install and tighten (4) #8-11 X 1 1/4" (Bag D & I) across the top of the where the blue or gray plastic meets the gray Roto Mold #5. See Figure 18.
22. Install and tighten (8) #10-32 x 1/2" (Bag F) (no washers) in the pedestal of the blue or gray plastic #5. See Figure 18. This completes the Roto mold and plastic installation.

Chapter 4: System Wiring

The main power input is wired to the terminal block which is located inside the top of the Auto Sentry Petro,



Warning Symbol

The Warning Symbol symbol (in this manual, on equipment, or hardware) indicates you should consult accompanying documentation before proceeding..

AC Power Terminations

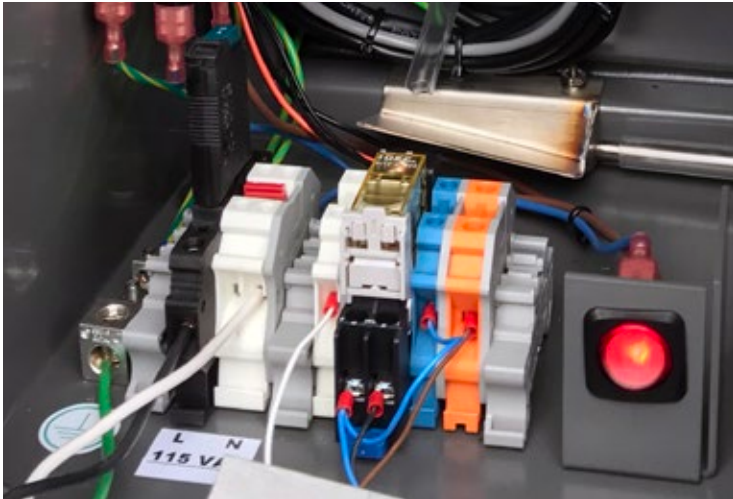

WARNING: The terminals and power supplies contained in the Auto Sentry Petro enclosure are for the ICS Equipment Only! Connecting external components and wiring to the Auto Sentry Petro power circuits can damage the circuit boards and components and WILL VOID THE WARRANTY.

Figure 21. Power Terminal blocks inside the Auto Sentry Petro

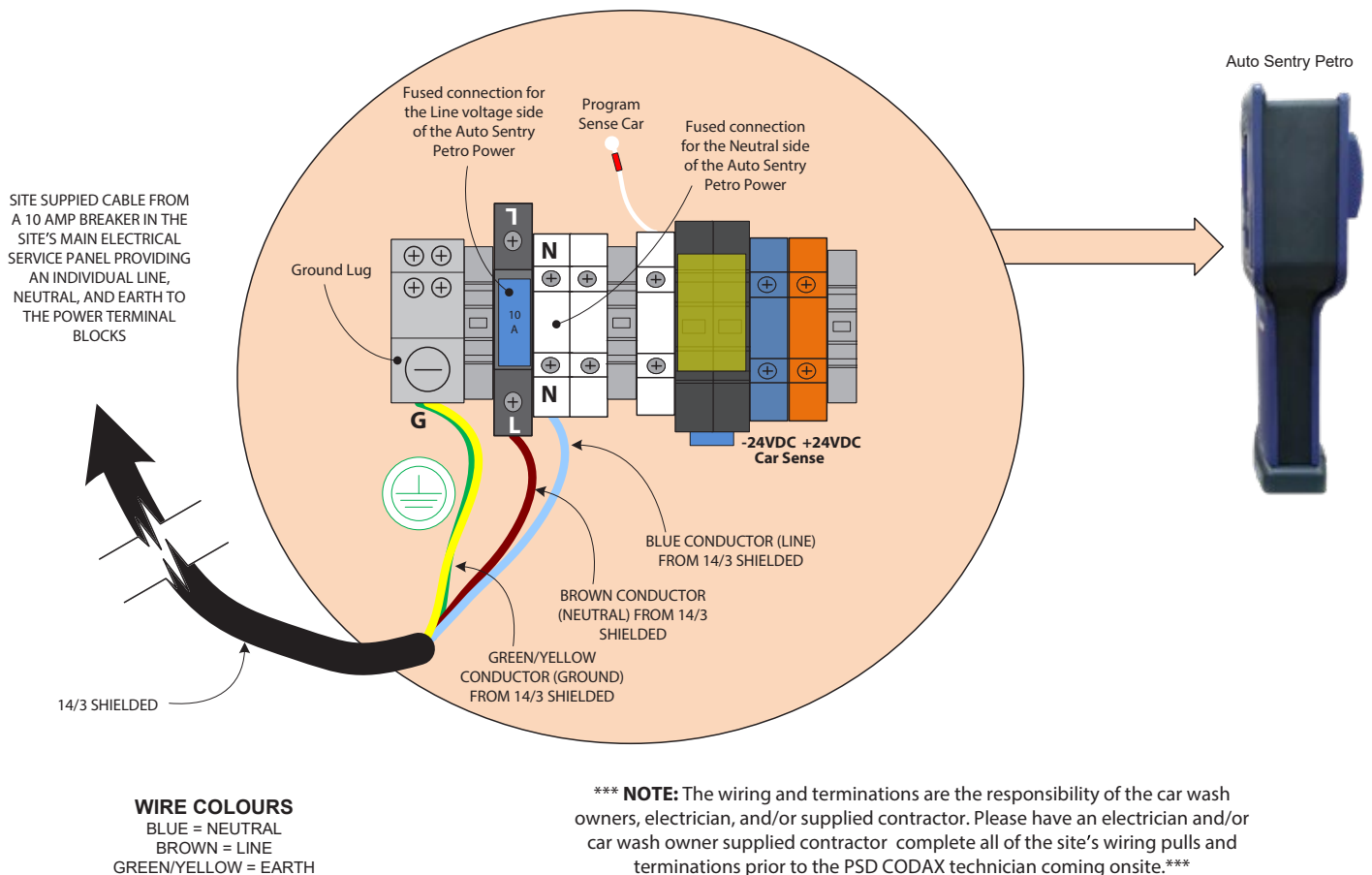

Figure 22. AC Power Terminations

Programming Sonic Sensor for Sense Car

These programming instructions are for the round green and white sonic sensor located on the front of the Auto Sentry Petro.

NOTE: These instructions are NOT for the orange sensor.

1. Put an object in front of the sonic sensor the same distance away from the Auto Sentry Petro where car would normally be when parked at the payment terminal. (A metal sign works best or something similar).
2. With the object in place, touch the white programming wire to the +24 orange terminal block, and the sensor flashes yellow. Hold until it flashes red, and then hold for a few more seconds.
3. Move the wire off of the +24 orange terminal block.
4. Move the object away from the area.
5. Touch the white programming wire to the -24 blue terminal block.
6. Sensor should flash red.
7. Move the wire off of the -24 blue terminal block.
8. Test the sensor, you should see the sense car on the PIO/SIO board light up.

If no signal, you can remove 3P9 cable and jump pins 3 and 4 on the board and check car sense light.

Power Wiring Plan

*** THIS DRAWING IS ONLY INTENDED TO SHOW THE TYPES OF WIRING THAT MUST BE RUN BETWEEN PIECES OF ICS EQUIPMENT. THE INDIVIDUAL RUNNING THE WIRING MUST ENSURE THAT AMPLE WIRE IS AVAILABLE AT EITHER END TO FACILITATE TERMINATION. THE TERMINATION POINTS OF THE CABLES ARE NOT SHOWN ON THIS DOCUMENT. ALL PERMANENT SITE WIRING CONNECTIONS MUST BE PERFORMED BY A LICENSED ELECTRICIAN THAT MUST COMPLY WITH ALL NATIONAL LOCAL RECOMMENDED STANDARDS. THIS DRAWING IS NOT TO SCALE.***

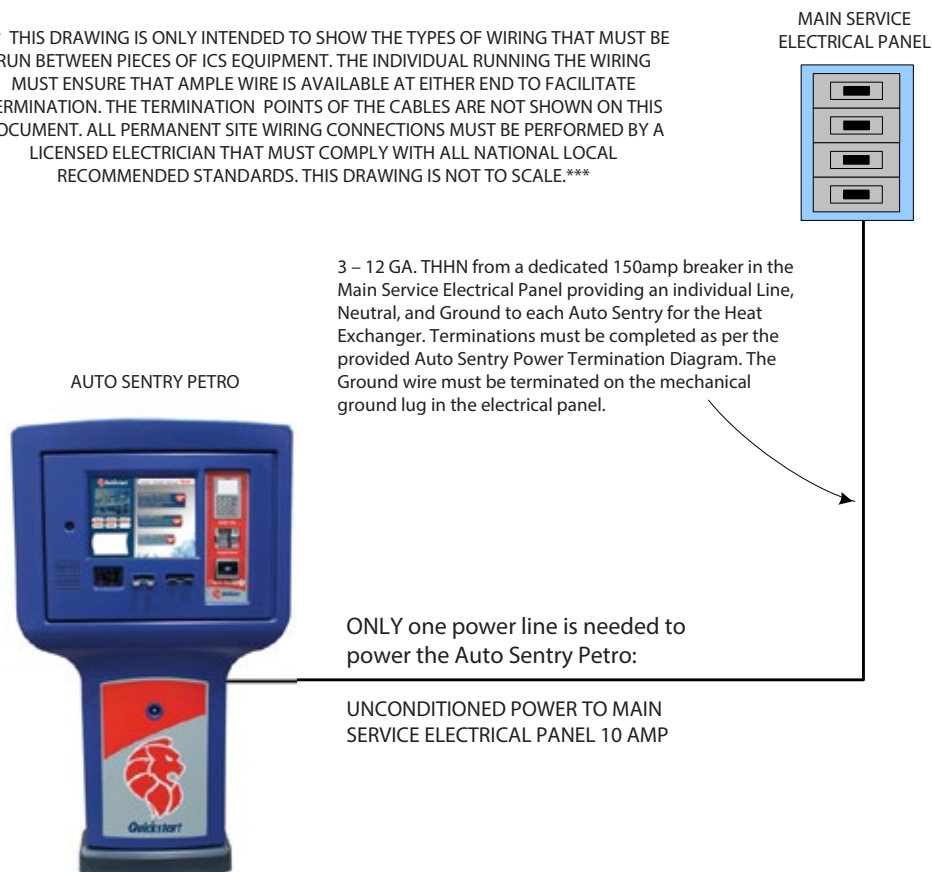

IMPORTANT:
Run only one power line to the Auto Sentry Petro.

Figure 23. Power Wire Layout

Control Box Terminations

The WashConnect software has the ability to toggle the Auto Sentry Petro Wash Open on the server / POS computer screen, and this feature is optional. Override switches for the gates are still necessary.

ALL ITEMS CIRCLED TO BE PROVIDED BY CAR WASH

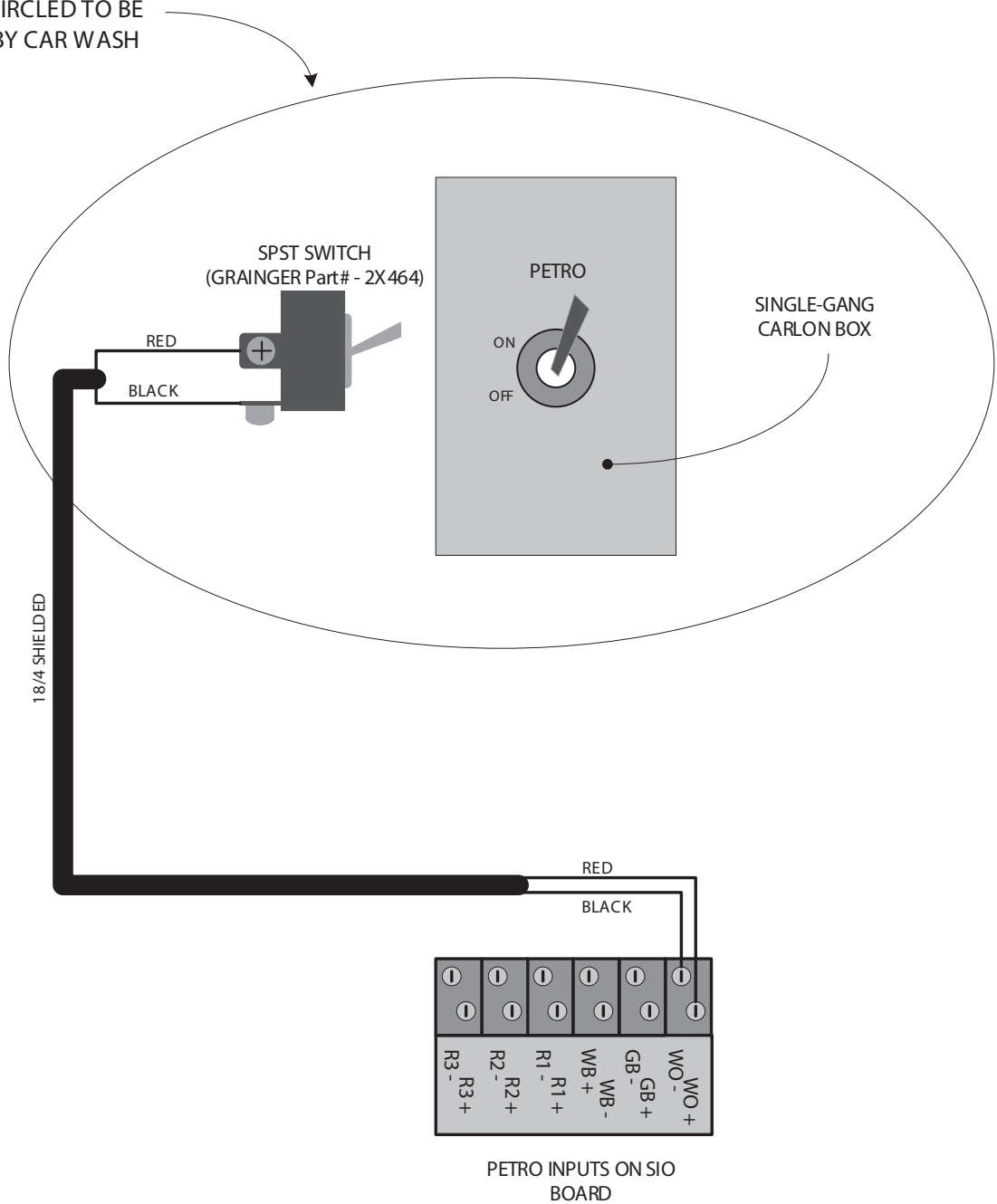
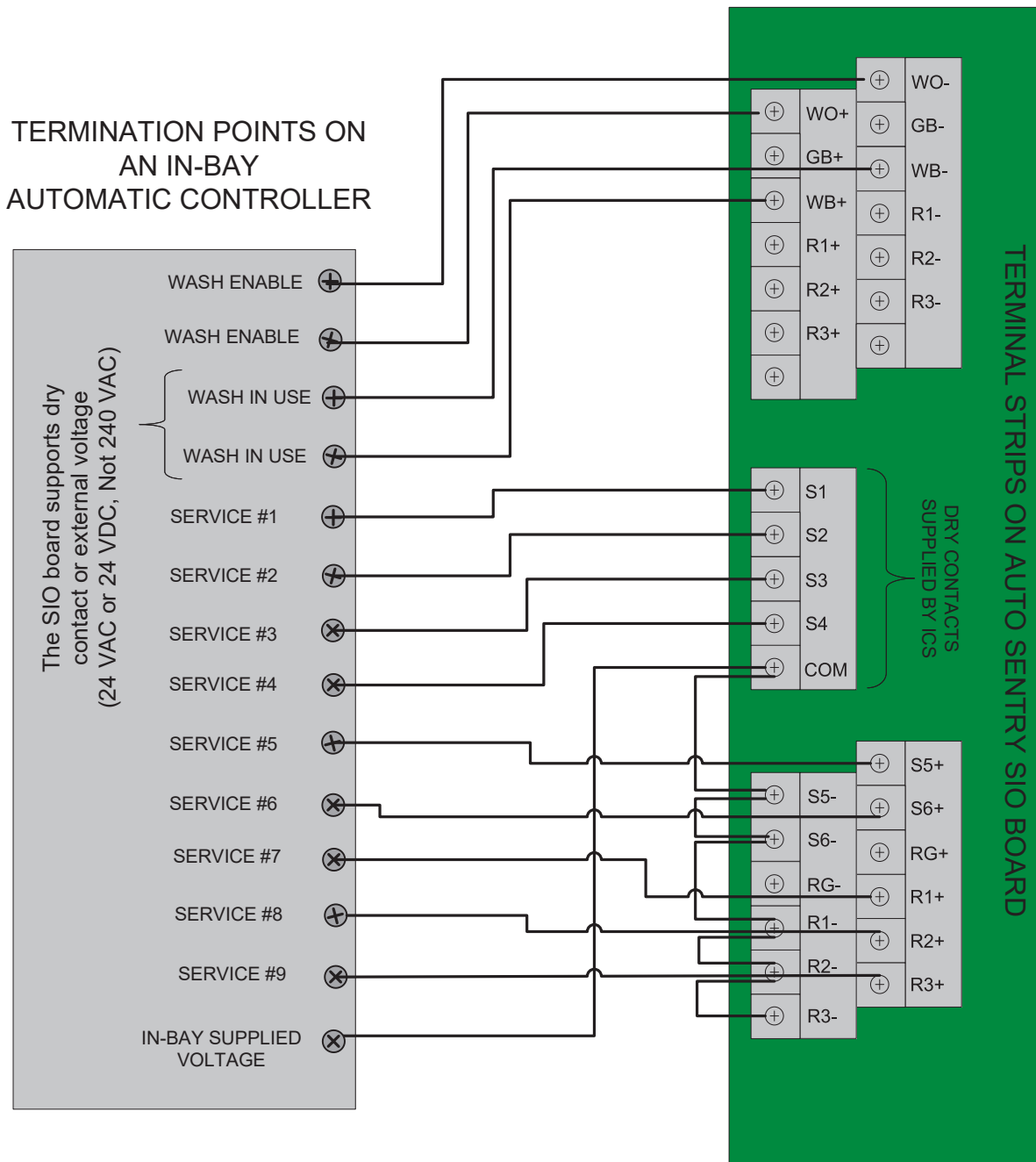

Figure 24. Control Box Terminations

In-Bay Controller Wire Terminations

NOTE: Some of the wiring shown may not be needed for all in-bays.



Terminology varies. For example, Wash Busy can also be called “wash in use” or “wash inhibit”.

NOTE: The SIO board supports up to direct wash outputs but also support several binary protocols for more functions if needed.

Figure 25. In-Bay Controller Wire Terminations

In-Bay Wiring Layouts

Figure 26 is one example of a possible wiring layout for an In-Bay Car Wash. See the PSD Codax System Installation Drawings that were prepared for your specific car wash site and given to you by your PSD Codax salesperson or technician.

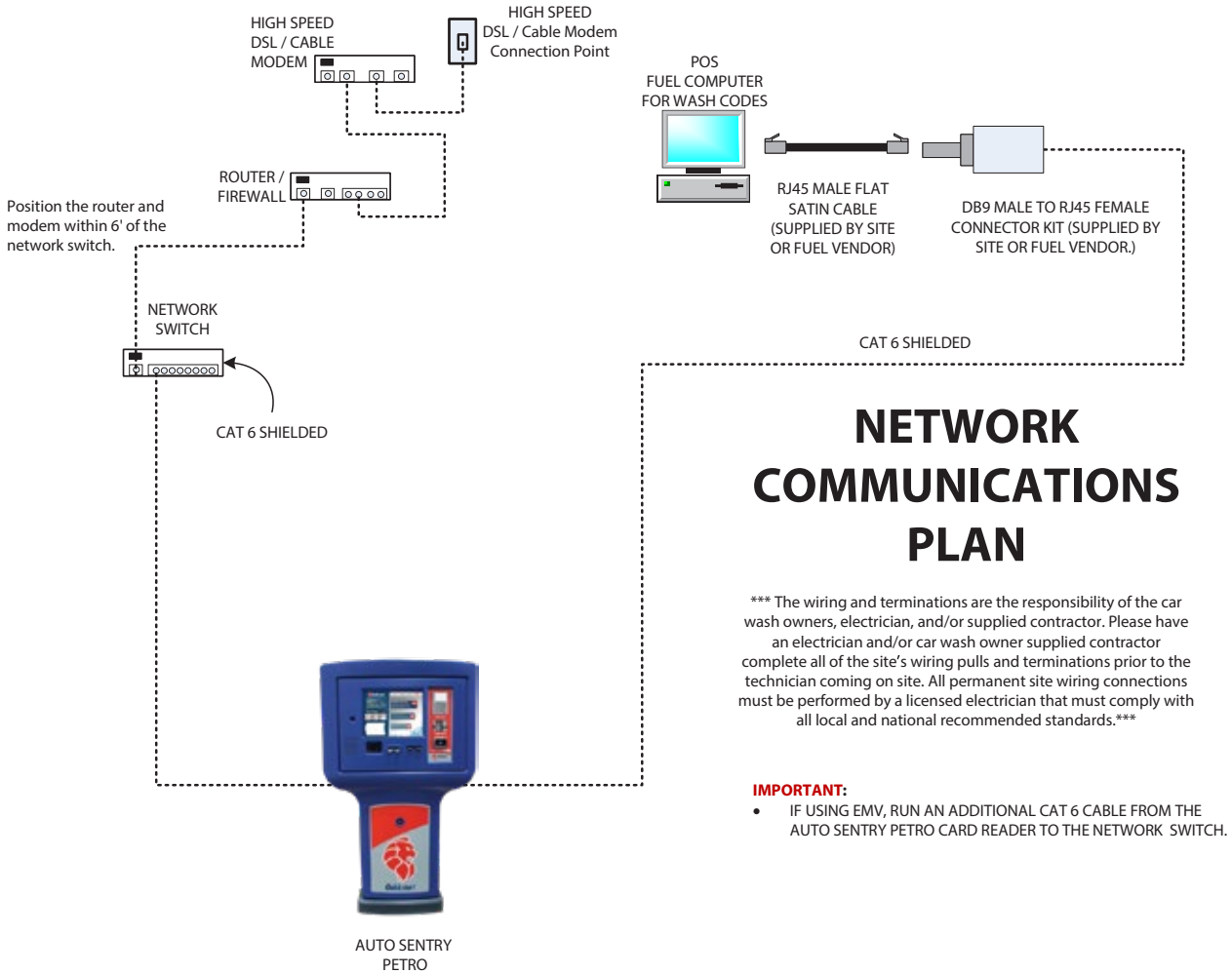

Figure 26. Single In-Bay Network Communication Plan

Communications Wiring

This section describes wiring for RS-422 and RS-485 communications.

Requirements

- All peripheral equipment connected to the RS-232 ports must be Listed, have an Electronics Industrial Association (EIA) standard RS-232 comm communications protocol and not be installed over a hazardous location.
- RS-232 communication must not exceed 30 m.
- Communications equipment signal wires must also be run in separate rigid PVC or metal conduit, separate from any power conduits.

Network Terminations

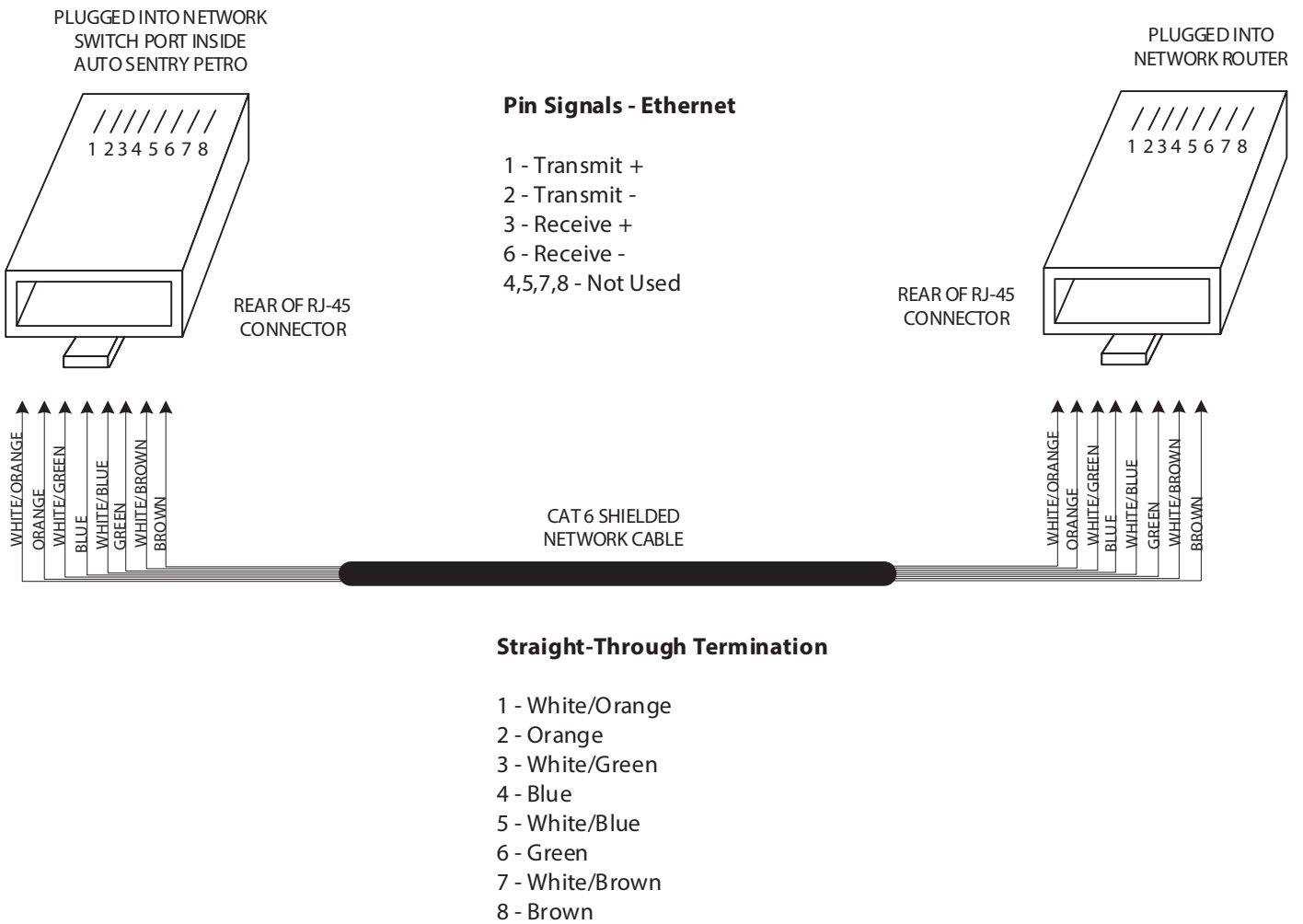

Figure 27. Network Terminations

System Network Cables

1. Plug a network cable into the Network Router, and then pull that network cable up through the center of the Auto Sentry Petro unit. Plug in the other end of this network cable to the Network Switch port located inside the Auto Sentry Petro. See the yellow cable in Figure 28. (It does not matter which port you use.)
2. The black network cable in Figure 28 is plugged into the Network switch port and runs to the UX300 card reader. A network coupling is located on the inside of the Petro to connect the network cable.
- NOTE: A network switch is only used outside the United States.
3. The blue cable in Figure 28 is plugged in the Network Switch and runs to the motherboard.



Figure 28. Network Switch

Chapter 5: Parts Identification

This section provides details on exterior and interior component locations. The Auto Sentry Petro also includes roto molds and plastic panels to fit the exterior of the unit. Panels may be purchased separately.

NOTE: If you cannot find the part in the following pages, contact PSD Codax sales for more information: email SALES@PSDCODAX.COM. Both exterior and interior components, wires, accessories, and more are available for purchase or reorder.

Exterior Components (Front View)



Figure 29. Exterior Components (Front View)

Table 1. Exterior Components (Front View)

| | ICS Part Number | Description |
|----|---------------------------|---|
| 1 | AS2TOUCH15Z2 | 15" touch screen with AR coating |
| 2 | CAMERAASSM CAMERAASSM1 | Camera assembly, with Chip & Pin equipment Camera assembly, WITHOUT Chip and Pin equipment |
| 3 | AS2INTERCOMSP | 2 Speakers |
| 4 | SCN-000002-00 | Bar code Reader |
| 5 | N/A | Gift card dispenser chute (Discontinued) |
| 6 | SENSOR-18MML | Replacement Sensor only |
| 7 | | PIN pad per site specifics |
| 8 | | Card reader assembly per site specifics |
| 9 | | Contactless reader per site specifics |
| 10 | ASPRHEC | USB printer |

Plastic and Roto Mold Parts

Please refer to "Plastic and Roto Mold Parts Identification" on page 11.

Power Terminal Blocks

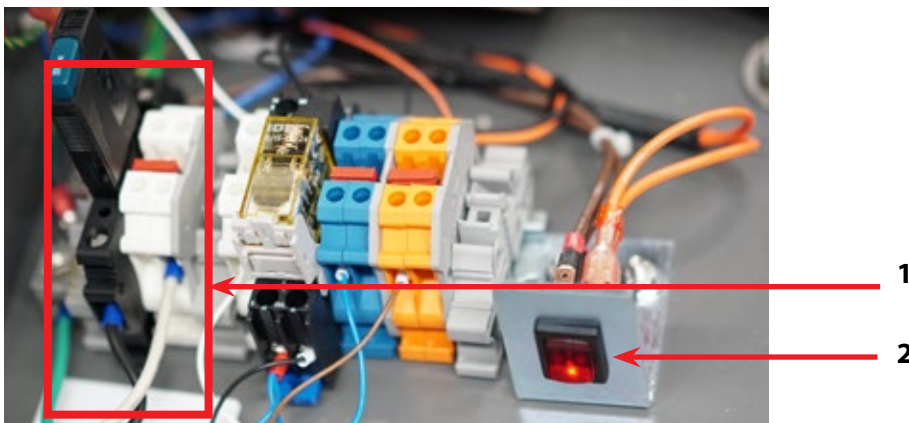

Figure 30. Power Terminal Blocks

Table 2. Power Terminal Blocks

| | ICS Part Number | Description |
|---|-----------------|---------------------------|
| 1 | AS4-TB-0-A | Power terminal block asds |
| 2 | AS4PWRSWITCH | Power switch, illuminated |

Interior Front Door Components

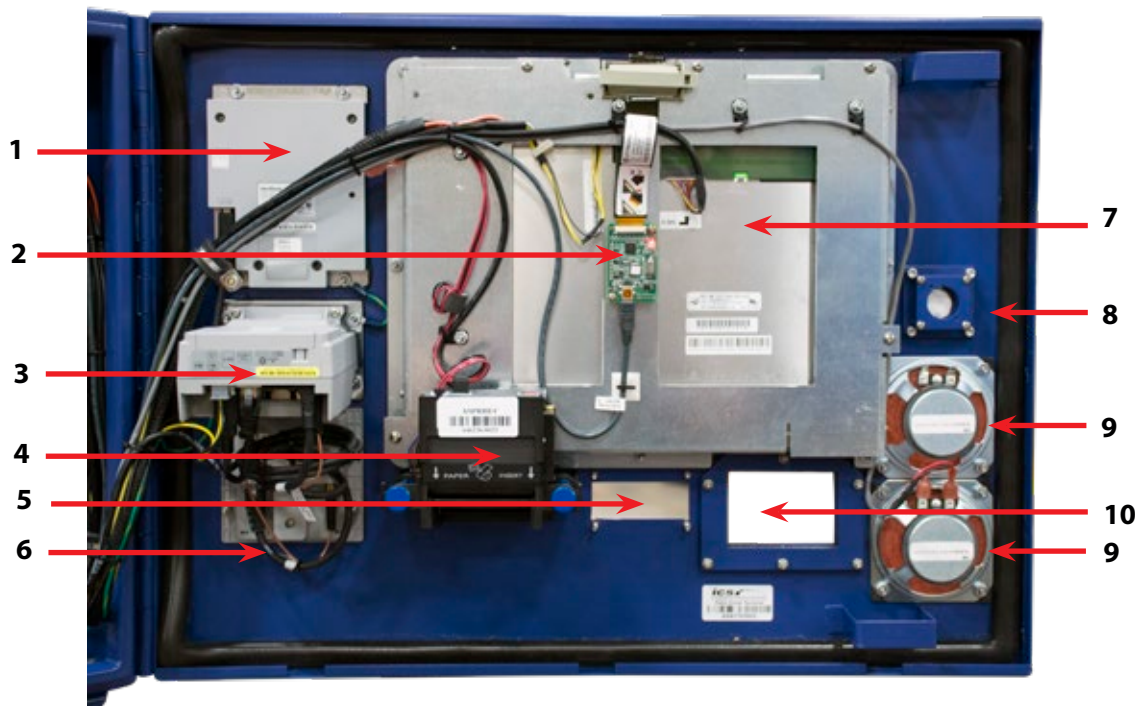

Figure 31. Interior Front Door Components

Table 3. Interior Front Door Components

| # | ICS Part Number | Description |
|----|---------------------------|---|
| 1 | | PIN Pad per site specifics |
| 2 | AS2TOUCH15ZCNCD | Touch Controller Card |
| 3 | | Card reader assembly per site specifics |
| 4 | ASPRHEC | USB Receipt Printer |
| 5 | N/A | Gift Card Chute (Discontinued) Card Dispenser (Discontinued) |
| 6 | | Contactless reader per site specifics |
| 7 | AS4DISPASSM | NEC Display Assembly |
| 8 | CAMERAASSM CAMERAASSM1 | Camera assembly, with Chip & Pin equipment Camera assembly, WITHOUT Chip and Pin equipment |
| 9 | AS2INTERCOMSP | 2 Speakers for the Auto Sentry Petro |
| 10 | SCANNERCOV | Window protector for Bar code Reader |

Interior Rear Left-Side of Auto Sentry Petro

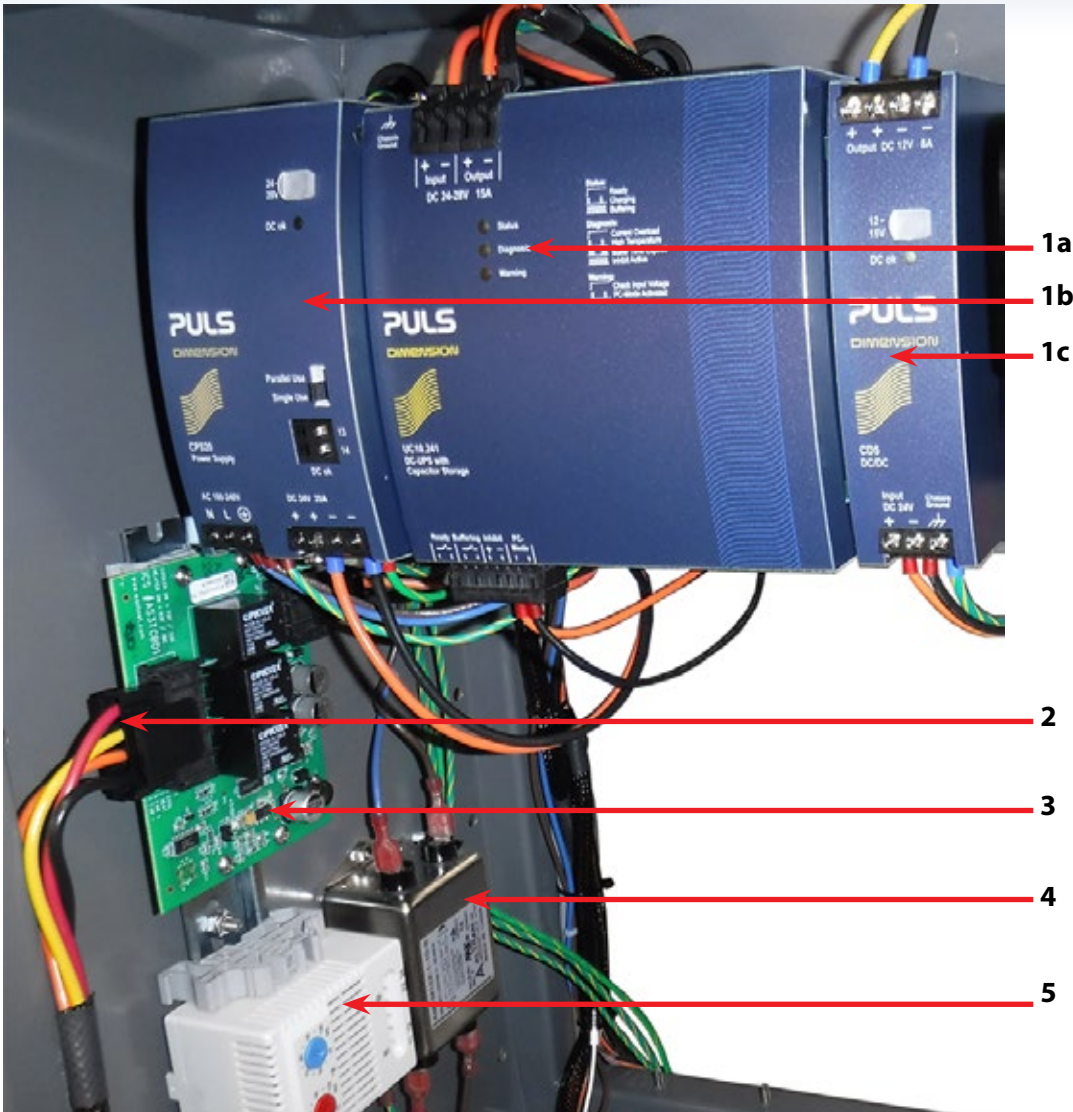

Figure 32. Interior Rear Left-side of Auto Sentry Petro

Table 4. Interior Rear Left-side of Auto Sentry Petro

| # | ICS Part Number | Description |
|----------------|---|---|
| | SURGEPROTECT 120 VAC SURGEPROTECT1 240 VAC | Surge Protector (Not Shown) |
| 1a 1b 1c | PWRPULSUPS PWRPULS24V PWRPULS12V | UPS 24VDC Power Supply 12VDC Power Supply |
| 2 | AS3CBL21A | 24 Volt (Low Voltage) power cable for the heat exchangers |
| 3 | H/CCONTROLBD1 | Heater/cooler control board |
| 4 | ASEMIFILTER | EMI filter for AC V |
| 5 | AS2THERMCOOL | Thermostat for cooling |

Interior of Rear Door Components

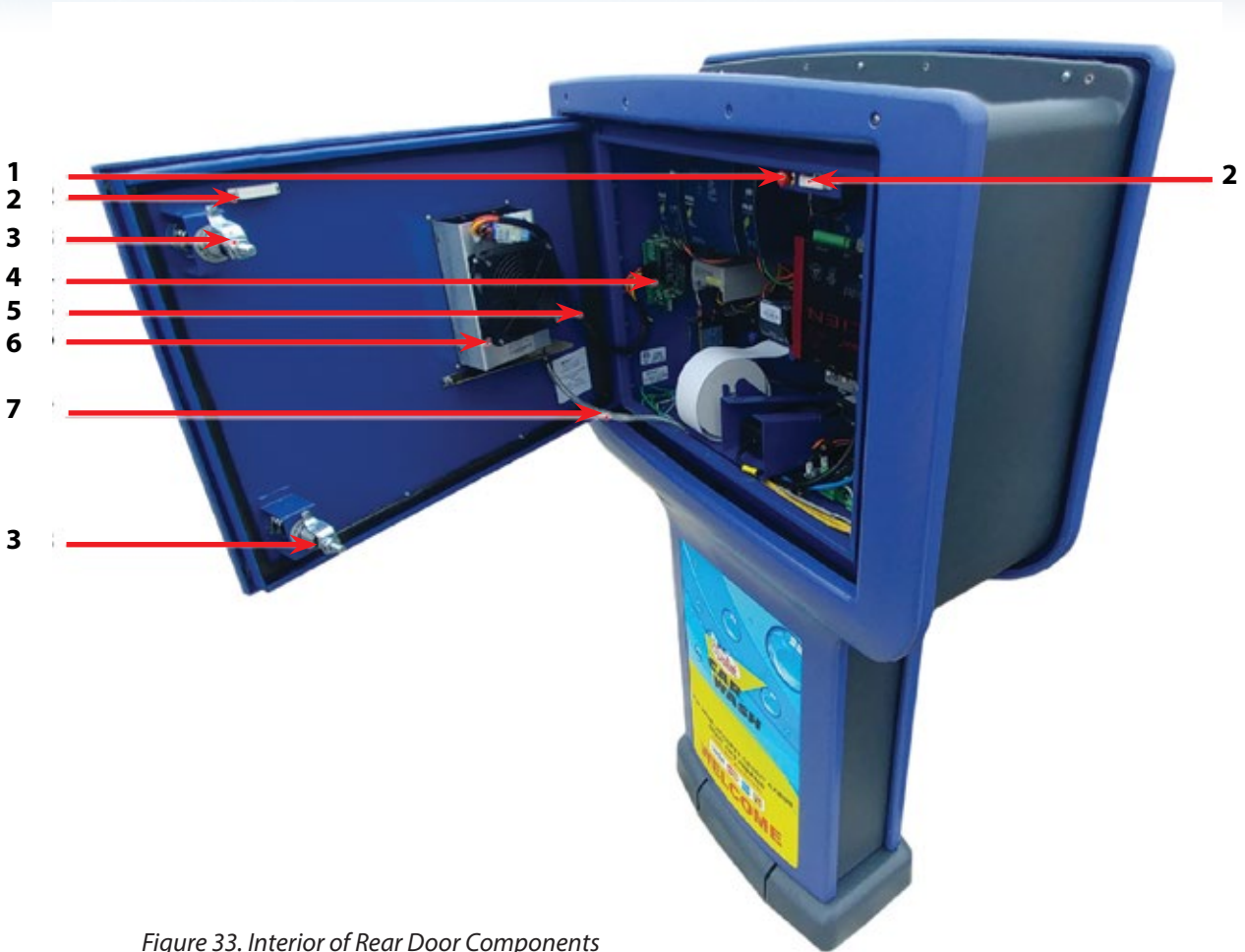

Figure 33. Interior of Rear Door Components

Table 5. Interior of Rear Door Components

| # | ICS Part Number | Description |
|---|------------------------------------|---|
| 1 | ASPUSHBUT | Service screen button |
| 2 | AS3DRSW | Door switch (2 pieces) |
| 3 | ASDRLATCH AS4DRKEY AS4DRLOCK | Complete latch assembly Key for AS4DRLOCK "ICS MEDECO KEYS" Door Lock for AS4, 64W0550T-26-M7-ICS-2 "ICS MEDECO KEYS" |
| 4 | H/CONTROLBD1 | Heater/cooler control board |
| 5 | AS3CBL21A | 24 Volt (Low Voltage) power cable for the heat exchangers |
| 6 | AS3HEATCOOL-1 | Heat exchanger assembly Includes heat exchanger (AS3HEATCOOL), cable with size 14 AWG wires for heating and cooling (AS2CBL52), and socket for heater relay (AS2HEATSOCK). |
| 7 | AS2HEATDRHOSE | 1.2 m condensation hose |

IMPORTANT: DO NOT RUN OUT of Auto Sentry flex HD keys!!! If the Auto Sentry flex HD keys go missing, replacing the key process can take 4 to 6 weeks, and it is costly.

Email PSD Codax Sales to replenish your key supply BEFORE you run out of keys completely at your wash site: SALES@PSDCODAX.COM

Interior Rear Right-side

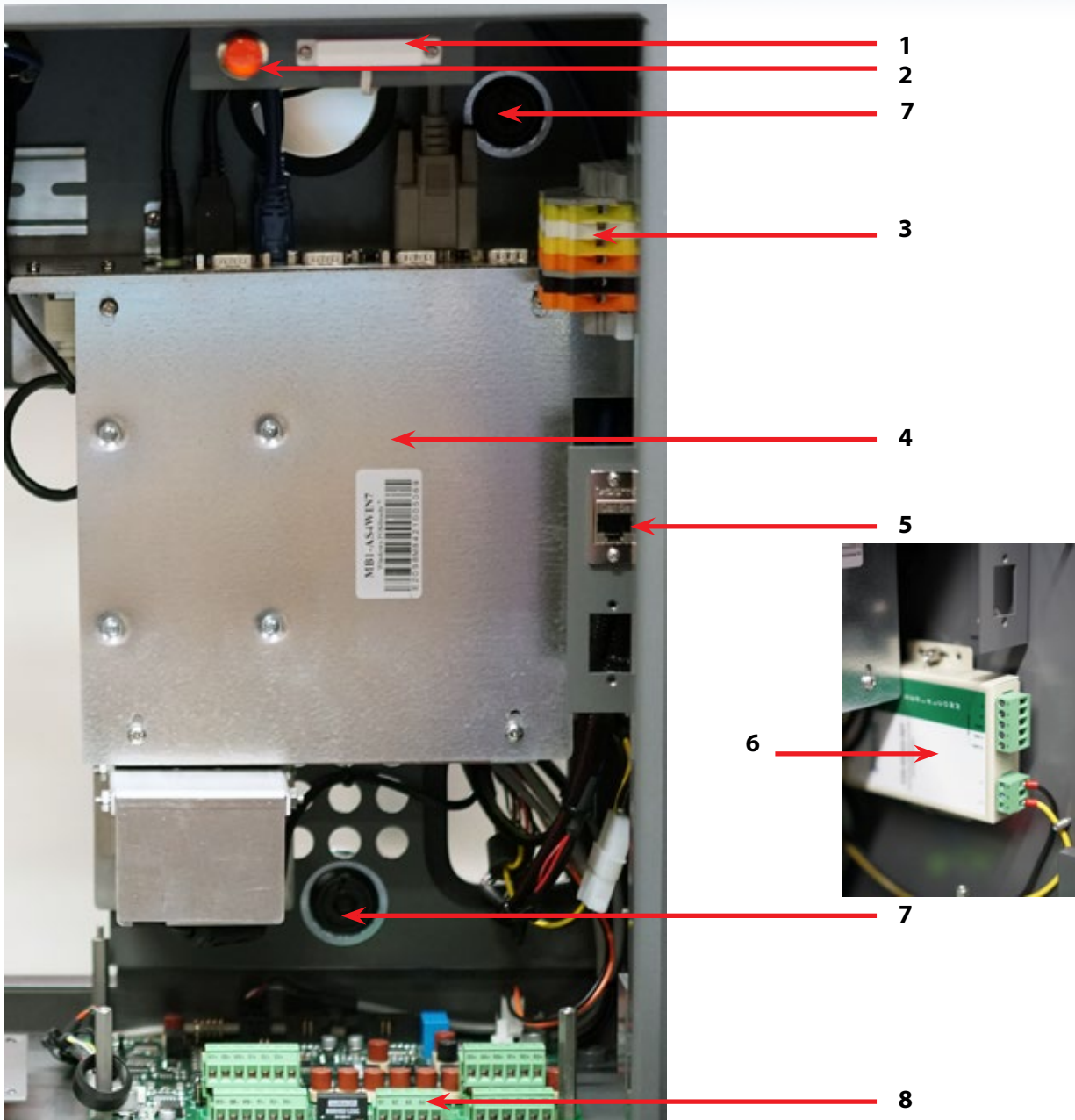

Figure 34. Interior Rear Right-side

Table 6. Interior Rear Right-side

| # | ICS Part Number | Description |
|---|-----------------|------------------------------------|
| 1 | AS3DRSW | Door Switch (2 pieces) |
| 2 | ASPUSHBUT | Service Screen button |
| 3 | AS4-TB-1-A | RFID Terminal Block Assembly |
| 4 | | Motherboard per site specifics |
| 5 | NETRJ45CO | Network Coupler |
| 6 | COMCONVEXPWR1 | Standard Fuel Converter (Optional) |
| 7 | ASDRLATCH | Latch Assembly |
| 8 | PCB-SIO002-01 | SIO board |



Environmental Statement

PSD Codax strives to create top quality products that minimize impact on the environment. We work with all our partners to produce products that are in compliance with the relevant environmental regulations and legislation.

We also recognize our responsibility to minimize the quantity of electrical and electronic waste reaching landfill. For this reason we encourage reuse or responsible disposal of waste electronic and electrical equipment (WEEE). All applicable products are marked with the crossed-out wheellie bin label to indicate the need for responsible disposal.

PSD Codax is a member of the Clarity Environmental Ltd Compliance Scheme in the UK.
Producer registration number WEE/GK0204VX.

Registered in England. Company Number 04204089



Defining the World of Car Wash Technology

Axis 8, Hawkfield Business Park, Hawkfield Way, Whitchurch, Bristol, BS14 0BY
Phone: +44 1275 866 910 | Fax: +44 1275 866 919 | Email: info@psdcodax.com