



PSD Codax

Global Leaders in Car Wash
Technology

CAT 5

(24 Character Display)

Operators Manual

**Secure, reliable, easy-to-use and
innovative**

Car Wash and Forecourt Equipment.

CAT-S24-UM-ENG-040319-1.01

www.psdcodax.com



Defining the World of Car Wash Technology

Smartstart Plus | Smartstart Pro | Auto Sentry® Petro | Auto Sentry® Flex | Auto Sentry® CPT | WashConnect®

REVISION HISTORY

Document Number	Version	Date	Comments
CAT-S24-UM-ENG-040319-1.01	1.01	04 March 2019	1 st Release

CODAX ACCESS TERMINAL OWNERS MANUAL

CODAX ACCESS TERMINAL OWNERS MANUAL

KEY

	Screen		Admin Smartcard Card
	Star/Cancel		Customer's Smartcard
	Enter/Accept		Card Invalid
	Key Pad		Writing to Card Successful
	Flow Correct		Blank Card
	Flow Incorrect		Card Invalid
	Clear		Insert Smartcard
	Expanded Menu		Remove Smartcard
	Correct		Value of Smartcard
	Incorrect		On
	Decision Required		Off
	Any Key		Timeout or Time Delay
	Drive In		Drive Out

CODAX ACCESS TERMINAL OWNERS MANUAL

CONTENTS

1	IMPORTANT SAFETY INFORMATION.....	9
2	CODAX SYSTEM INSTALLATION	11
2.1	SUMMARY OF CODAX SYSTEM COMPONENTS.....	11
2.2	CODAX SYSTEM COMPONENTS	12
2.2.1	CODAX TICKET TERMINALS.....	12
2.2.2	CODAX ACCESS TERMINALS.....	13
2.2.3	INSTALLATION OPTIONS	14
2.3	STANDARD CONNECTIONS – ULTRA or RETRO	16
2.4	INSTALLATION EXAMPLES.....	17
2.4.1	STANDARD ULTRA CABLED CONNECTION	17
2.4.2	STANDARD RETRO CABLE-FREE CONNECTION	18
2.4.3	DUAL TICKET TERMINAL IN AN ULTRA SYSTEM	19
2.4.4	DUAL TICKET TERMINAL IN A RETRO SYSTEM.....	20
2.4.5	DUAL RETRO CONNECTION	21
2.4.6	NETWORKED RETRO CONNECTION	22
2.4.7	COMBINED CONNECTION.....	23
2.5	TERMINAL LAYOUT	24
2.5.1	ACCESS PANEL	24
2.5.2	NUMERIC ENTRY KEY PAD	24
2.5.3	FUNCTION KEYS.....	24
2.6	MACHINE INSTALLATION & MAINTENANCE	25
2.6.1	POWERING UP THE ACCESS TERMINAL	25
2.6.2	INITIAL TEST MODE.....	27
2.6.3	MACHINE LINK CONTROL	27
2.6.4	MACHINE LINK SIGNALS	28
2.7	MACHINE LINK CONTROL	29
2.7.1	E2PROM MACHINE TABLE	29
2.7.2	AUXILARY TABLE (JET WASH, VACUUM AND AIR).....	30
2.7.3	MACHINE TEST TICKETS.....	31
2.7.4	TEST TICKET LAYOUTS.....	32
2.7.5	Test Wash Operational Sequence.....	33
3	TERMINAL CONFIGURATION	35
3.1	ACCESSING SYSTEM SETUP	35
3.2	USER SETUP MENU	36

CODAX ACCESS TERMINAL OWNERS MANUAL

3.2.1	SETUP OPTIONS.....	36
3.2.2	SET TIME AND DATE	37
3.2.3	SELECT LANGUAGE (OPTIONAL UPGRADE).....	38
3.2.4	SELECT LINK MODE.....	39
3.2.5	SYSTEM SETUP.....	40
3.2.6	SET PROGRAM BASE (RETRO ONLY)	41
3.2.7	MACHINE SETUP.....	42
3.2.8	OFF PEAK SETUP (RETRO ONLY).....	43
3.2.9	SMARTCARD SETTINGS (OPTIONAL UPGRADE)	44
3.2.10	DUAL RETRO (OPTIONAL UPGRADE)	46
3.2.11	WASH QUEUING.....	47
3.2.12	PROGRAM BLOCKING	48
3.2.13	SITE CLOSURE	49
3.2.14	SOFTWARE VERSION	50
3.3	ACCESS CODES	51
4	MACHINE SETUP.....	56
4.1	AUXILIARY MACHINE SETUP	56
4.1.1	TIMED OUTPUT MODE	57
4.1.2	PULSED OUTPUT MODE.....	58
4.2	BRUSH WASH MACHINE SETUP	60
4.2.1	OPERATING MODES.....	60
4.2.2	MACHINE INPUTS	60
4.2.3	PROGRAM SELECTION/START OUTPUTS.....	61
4.2.4	APPLICATION OF PROGRAM CONTROL SIGNALS	61
4.2.5	MACHINE SETUP SEQUENCE	62
4.3	MACHINE OUTPUT CONTROL SIGNAL VARIATIONS.....	63
5	USER FUNCTIONALITY	66
5.1	CODAX CODE ENTRY	66
5.1.1	NUMERIC CODE ENTRY.....	66
5.1.2	BARCODE ENTRY.....	66
5.1.3	MULTI-USE TICKETS (ULTRA OPTION).....	67
5.1.4	OFF-PEAK CODES	67
5.1.5	INVALID CODE ENTRY	68
5.1.6	KEYING ERROR.....	68
5.2	FROST SHUTDOWN.....	69
5.3	SITE OPERATING TIMES	69

CODAX ACCESS TERMINAL OWNERS MANUAL

5.4	BLOCKED PROGAM	70
5.5	MACHINE RUNNING SEQUENCES	71
5.5.1	BRUSH WASH UK MODE	71
5.5.2	BRUSH WASH UK MODE WASH QUEUING.....	72
5.5.3	BRUSH WASH EURO MODE	73
5.5.4	AUXILIARY	74
5.6	SMARTCARD	76
5.6.1	CARD PLACEMENT	76
5.6.2	USER CARD TYPES	76
5.6.3	SMARTCARD SYSTEM MAINTENANCE	77
5.6.4	SMARTCARD TRANSACTIONS.....	78
5.6.5	FAILED TRANSACTION.....	80
5.7	ACCESS NETWORK CONTROLLER (ANC).....	83
5.7.1	ANC SETUP.....	83
5.7.2	ANC SETUP MENU	83
5.7.3	ANC ACCESS CODES.....	84
5.7.4	OFF-PEAK IN AN ANC SYSTEM	84
5.7.5	ANC STANDARD SYSTEM SETUP	85
5.7.6	ANC EXPANDED SYSTEM SETUP.....	86
6	TROUBLE SHOOTING	87
6.1	CODAX SYSTEM FAULT CODES.....	87
6.1.1	FAULT CODE 1 – MACHINE LINK ERROR	87
6.1.2	FAULT CODE 2 – MACHINE POWER FAILURE.....	87
6.1.3	FAULT CODE 3 – KIOSK LINK FAILURE (ULTRA ONLY).....	88
6.1.4	FAULT CODE 4 – KEYPAD FAULT	88
6.1.5	FAULT CODE 5 – ACCESS LINK ERROR.....	89
6.1.6	CODAX SYSTEM ERROR REPORT	89
6.2	CDU LED INDICATORS	90
6.2.1	CDU POWER INDICATION	90
6.2.2	CDU SIGNAL INDICATION.....	90
7	CONTACT INFORMATION	91

1 IMPORTANT SAFETY INFORMATION

Prior to installing or operating this equipment, please read this Important Safety Information carefully.

Codax must only be installed and serviced by a competent person who has sufficient electrical systems and product service knowledge. End users/owners must not attempt any service operations or remove any covers.

Removal of any covers, especially at the car wash/service interface keypad may expose high voltage electrical components and risk of electrical shock which can cause serious injury and death.

Car wash machines are often powered by a 415/420 volts three-phase electrical supply. Such supplies are extremely dangerous when unqualified persons attempt to service/touch them, presenting a very high risk of instant death.

CE

- The person(s) responsible for installing or commissioning Codax must ensure that the Owner/Operator Manual is presented to the owner / operator of the system.
- The CE mark applying to Codax relates to Codax as a standalone system. It is the responsibility of the installer and or equipment manufacturer to ensure that the integrity of Codax or the equipment, especially the electrical integrity, is not affected or compromised in any way.
- The Codax 24VDC power supply unit (12VDC for printer-less POS linked Terminals) and Codax Ticket Terminal must be installed in a dry environment and only connected to an electrical supply that has been installed by a qualified electrician.
- The Codax Ticket Terminal/Codax Embedded Terminal must only be powered by a Codax 24VDC/12VDC Power Supply unit - It must never be connected to other power supplies and never connected directly to the mains electrical supply.
- The Codax Ticket Terminal/Codax Embedded Terminal is designed to be installed and operated indoors. Do not allow fluids to enter or to be splashed onto it.
- The Codax system or components are not designed to be installed or operated in hazardous areas.
- Check that the machine is safe to operate and clear of persons and property before testing at the end of the installation process.



- At end of life dispose of Waste Electrical and Electronic Equipment (WEEE) responsibly.

Codax™ is designed and manufactured by PSD Codax Ltd.

Axis 8, Hawkfield Business Park
Whitchurch
Bristol, BS14 0BY
England
www.psdcodax.com

CODAX ACCESS TERMINAL OWNERS MANUAL

Codax software copyright notice.

When you purchase each single Codax system you are granted a single licence to operate the one version of the operating system supplied with the hardware. No permission is granted to resellers or end purchasers to make copies of this software. Software changes or upgrades supplied by PSD by download or module format are for a single installation and must not be copied. Again a single licence is granted with each download or module. You are advised not to purchase or operate illegal versions of Codax software.

© 2019 PSD Codax Limited – All Rights Reserved

2 CODAX SYSTEM INSTALLATION

2.1 SUMMARY OF CODAX SYSTEM COMPONENTS

The PSD Codax system generally consists of items from the following component list and will depend on the clients purchase order instructions. Always check customer instructions and packing note to determine components required.

Please refer to Codax sales information to identify the features available according to the desired installation mode. In Retro (Cable-free) mode certain features and functions will not be available.

CTT	Codax Ticket Terminal – Standard unit
CTT-Ex	Codax Ticket Terminal – Extended database version
CTT-S	Codax Ticket Terminal Secondary – Add a second Ticket Terminal to an Ultra (Cabled) installation
CET-Ser	Codax Embedded Terminal – For Serial POS linked installations
CET-Eth	Codax Embedded Terminal – For Ethernet POS linked installations
CTT-POS-Ser	Codax Ticket Terminal - With Serial POS connection, including Smartcard
CTT-POS-Eth	Codax Ticket Terminal - With Ethernet POS connection, including Smartcard

Ticket Terminal Upgrades:

SCU-CTT	Smartcard Upgrade for CTT – Add a Smartcard reader to CTT
WCB	Wash Connect Bridge – Optional upgrade to add access to Wash Connect

Access Terminals:

CAT-16	Standard Bezer Mount Codax Access Terminal – 16 Character display version
CAT-24	Flush mount Codax Access Terminal – 24 Character display version
CAT-ANC-16	CAT ANC Secondary Terminal – 16 Character display version
CAT-ANC-24	CAT ANC Secondary Terminal – 24 Character display version
SCU-CAT	Smartcard Upgrade for CAT – Add a Smartcard reader to CAT
BSM-CAT	Barcode Scanner Module – Optional upgrade kit for CAT

Installation:

CDU	Codax Distribution Unit – Distributes signal and power for Ultra (Cabled) installations
CPS24-xx	Codax 24VDC Power Supply unit – For Retro (Cable-free) installations
CPS12-UK	Codax 12VDC Powers Supply unit – For CET Retro installations
CPS-CAT	24VDC Power supply for Codax Access Terminal – Option for Retro connected machines without suitable 24VDC power supply
CWIIK	Car Wash Interface and Installation Kit – Machine specific for CAT installation
CAT-HP	Codax Access Unit Housing with bi-directional Pedestal
CAT-HW	Codax Access Unit Housing with Wall mounting bracket
MK-CAT	Mounting Kit for Codax Access Terminal – When Access Unit housing is not required
POS-LK	Point Of Sale Link Kit
DRK-232	Dual Retro Kit for RS232
DRK-485	Dual Retro Kit for RS485

ANC	Access Network Controller – Local network controller for multiple services of same type
ANC-Ex	Access Network Controller – Expanded version
BBX-232	Breakout Box for RS232
SER-232	Serial Router for RS232

2.2 CODAX SYSTEM COMPONENTS

2.2.1 CODAX TICKET TERMINALS

The Codax Ticket Terminal in its various forms is the central controller for all Codax installations. From here the system is configured and Ticket sales are made. The CTT is normally situated on the kiosk sales desk convenient for the sales person. Adequate space should be allowed behind to allow cable access.

Ticket Terminal variations:

CTT	Codax Ticket Terminal - Standard version for generating Codax codes stand alone with printer.
CTT-Ex	Codax Ticket Terminal with Extended Database Range. Similar to standard version but uses an extended database range to allow both terminals to operate on the same installation. Add a second Ticket Terminal to a Retro installation.
CTT-S	Codax Ticket Terminal Secondary – The Codax Ticket Terminal Secondary unit allows a second Ticket Terminal to be added to provide a second ticket sales point. Codes issued at the Secondary Terminal are requested from the Primary Ticket Terminal. This is normally for Ultra (Cabled) installations as it requires a CDU. For Retro the CTT-Ex may be a better solution – See installation examples.
CET-Ser	Codax Embedded Terminal – Serial – Codax code generator with Serial POS link without printer in smaller housing.
CET-Eth	Codax Embedded Terminal – Ethernet – Codax code generator with Ethernet POS link without printer in smaller housing.
CTT-POS-Ser	Codax Ticket Terminal POS linked – Serial – Codax code generator with Serial POS link with printer and Smartcard in standard CTT housing.
CTT-POS-Eth	Codax Ticket Terminal POS linked – Ethernet – Codax code generator with Ethernet POS link with printer and Smartcard in standard CTT housing.

The following items are available as upgrades to the standard Ticket Terminals list above.

Smartcard Upgrade for Codax Ticket Terminal CTT (SCU-CTT)

This upgrade is available for CTT and CTT-S to allow the Codax Smartcard to be added to the system. This option should be added at the time of CTT purchase as this is an internal fit and may not be added retrospectively. This upgrade is not available for CET. If POS link and Smartcard is required, CTT-POS should be used.

Wash Connect Bridge (WCB)

The Wash Connect Bridge connects to Wash Connect. Contact PSD Codax for more details. See *Contact details at the end of this manual, 7 - CONTACT INFORMATION.*

2.2.2 CODAX ACCESS TERMINALS

The Codax Access Terminal is fitted at the car wash machine or other service controller and it is where the customer redeems the unique Codax code purchased. The CAT provides the control signals required to operate the wash service and is capable of operating all common automatic car wash machines. Auxiliary service controls are also available to operate manual services such as Jet-Washes and Vacuum stations. For cabled installations (Ultra), the CAT is linked to the Codax Distribution Unit at the sales point via a 4-core screened cable. For cable-free installations (Retro) no such link is required – refer to installation examples.

Two Access Terminal variations:

CAT-16	Standard version with a 16 character display mounted in a water resistant housing.
CAT-24	Flush mount version with a 24-character display mounted on a flush mountable panel.

ANC Secondary Terminal (CAT-ANC-16/24)

The CAT-ANC is a special version of the CAT when using the Access Network Controller – see Installation examples. When using the Codax Access Terminal as an ANC-Secondary Terminal, two versions are available for 16 and 24 character displays as for standard unit defined above

The following items are available as upgrades to the standard Ticket Terminals list above.

Smartcard Upgrade for Codax Access Terminal CAT (SCU-CAT)

This upgrade is available for CAT to allow the Codax Smartcard to be added to the system. The SCU-CAT is part of the CAT installation and may be fitted retrospectively with a modified CAT mounting panel.

Barcode Scanner Module for Codax Access Terminal (BSM-CAT)

The Barcode Scanner Module is an optional addition to the Codax Access Terminal installation. With Barcode printing enabled on the Ticket Terminal the 6-digit Codax code is printed in the form of a barcode that the user can scan at the Access Terminal instead of manual entry. The BSM-CAT is part of the CAT installation and may be fitted retrospectively with a modified CAT mounting panel.

2.2.3 INSTALLATION OPTIONS

Codax Distribution Unit (CDU)

The CDU is only required for Ultra (Cabled) installations. The CDU is designed to be wall mounted using the brackets supplied. The unit should not be covered as overheating could occur. The unit requires a 240 Volt AC electric supply fused at 5 amps. The CDU receives the cable connections from the Codax Ticket Terminal, Point of Sale Terminal (optional) and the Codax Access Terminal(s). This unit provides 24VDC power supply to the CTT and CAT(s). A standard 5 metre connection lead is supplied for connecting the CDU to the Codax Ticket Terminal.

A single CDU connects to a maximum of 4 CATs. This however may be easily expanded – Contact PSD Codax for expansion possibilities. See *Contact details at the end of this manual, 7 - CONTACT INFORMATION.*

Codax Power Supply unit - 24VDC (CPS24-xx)

This is for Retro (Cable-free) installations to provide a 24 Volt DC power supply for the CTT and should therefore be located in a suitable and convenient location close to the CTT. A standard 5 metre connection lead is supplied for connecting this unit to the CTT. This is supplied for CTT and CTT-POS Retro installation.

Four versions are available to suit the local power outlet:

CPS24-EU	European style plug
CPS24-UK	UK style plug
CPS24-US	US style plug
CPS24-AX	Auxiliary No plug

Codax Power Supply unit - 12VDC (CPS12-UK)

This is lower-cost, lower-power PSU alternative, suitable for the CET only. Available with UK style plug only.

Codax Power Supply for Codax Access Terminal (CPS-CAT)

This 24VDC power supply is available to provide power for the CAT if this is not available at the machine installation. This is not necessary for an Ultra installation where power is supplied via the cable to the CDU.

Car Wash Interface and Installation Kit (CWIIK)

This is a machine specific kit according to the installation. This includes a 6/16 way interface (as required), cabling and including CAT – language and machine variant.

Mounting Kit for Codax Access Terminal (MK-CAT)

Hardware mounting kit for the Standard CAT (16-character). This is a non-flush-mount for installation into the operators own cabinet design.

Codax Access Terminal – Housing Pedestal (CAT-HP)

Pedestal Housing kit for the Standard and Flush-mount CAT (24-character). This housing includes front panel, with Smartcard and Barcode options, top box surround and pedestal leg.

Codax Access Terminal – Housing for Wall mounting (CAT-HW)

Wall Mounted Housing kit for the Standard and Flush-mount CAT. This housing includes front panel, with Smartcard and Barcode options, top box surround and wall mounting kit.

Point Of Sale Link Kit (POS-LK)

Connection kit for CTT to POS. Cable for single POS connection. Codax Serial Router included for multiple POS connection.

Dual Retro Kit for RS232 link (DRK-232)

This kit allows two CAT terminals to be connected and handle the Dual Retro operation mode over RS232. This kit includes two Current Loop Drivers (CLD) with connections to CAT. The CLD not only provides an extended operating range but also maintains dual mode functionality if the power to either machine is removed for maintenance.

Dual Retro Kit for RS485 link (DRK-485)

This kit allows two CAT terminals to be connected and handle the Dual Retro operation mode over RS485. This kit includes two Dual Link Power Loop (DLPL) with connections to CAT. The DLPL maintains dual mode functionality if the power to either machine is removed for maintenance.

Access Network Controller (ANC)

The ANC allows three or more machines of the same type to be connected for Retro installations up to a maximum of eight. An example of this is a Jet Wash with three or more bays. A single ticket for Jet Wash may then be used at any Jet Wash bay. The ANC provides a local comms network linking the CATs in this installation. See installation examples for the ANC configuration.

Access Network Controller Expanded (ANC-EX)

Expanded ANC increases the maximum number of machines networked, to sixteen.

Breakout Box for RS232 (BBX-232)

This unit is used to add a Secondary CTT to an installation or a single POS connection for CET.

Serial Router for RS232 (SER-232)

This unit allows up to 3 POS terminals to be added to an installation for CET.

2.3 STANDARD CONNECTIONS – ULTRA or RETRO

The basic Codax system has a number of Codax Access Terminals (CAT) connected to and controlling the forecourt services and a Codax Ticket Terminal (CTT) located within the sales kiosk. Tickets, for a specific service and program number, purchased at the kiosk and issued by the Ticket Terminal contain a six-digit Codax code that is redeemed when entered at the Access Terminal and the wash is started.

Each Access Terminal can operate in one of two modes, Ultra and Retro. This is determined by the installation and how service codes are issued and validated. The main difference between the two modes is in the connection of the CTT to CAT. For Ultra (cabled), the CTT is connected to the CAT via the Codax Distribution Unit (CDU). For Retro (cable-free) no physical connection between CTT and CAT is required.

Some additional functionality is available at the CTT when operating in Ultra mode, such as Multi-use tickets and connection to the ICS Wash Connect facility. This installation requires cross-forecourt cabling.

Contact PSD Codax to discuss specific installation requirements. See *Contact details at the end of this manual, 7 - CONTACT INFORMATION.*

2.4 INSTALLATION EXAMPLES

2.4.1 STANDARD ULTRA CABLED CONNECTION

In an Ultra configured system all the Codax Access Terminals (CAT) operating in this mode are connected to the Codax Ticket Terminal (CTT) via the Codax Distribution Unit (CDU). Each CAT is issued with set-up code which it uses to synchronise with the CTT. Unique set-up codes are issued for all the different service types, Brush Wash, Jet Wash etc., configured to the system. For installations with CATs connected to two or more of the same service type, the same set-up code is used. No additional equipment is required for an Ultra installation in this instance.

The Ultra database within the CTT contains information on every ticket issued by the system. Using this information the validity of a ticket is checked when requested by the CAT.

The installation example below shows a typical Ultra mode connection for two Brush Wash services, a Jet Wash and a Vacuum bay.

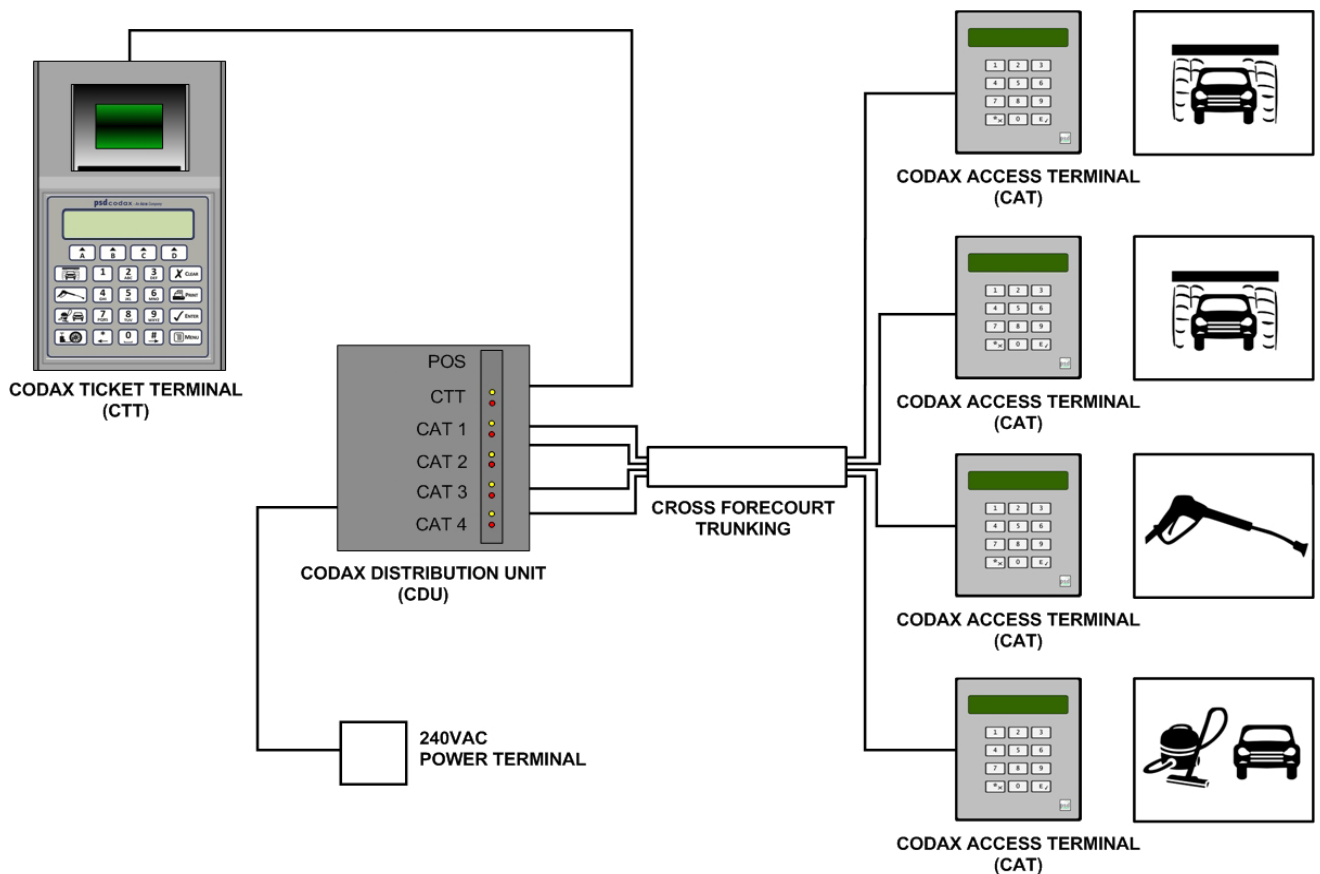

Standard Codax Installation Example for Ultra Mode

CODAX ACCESS TERMINAL OWNERS MANUAL

2.4.2 STANDARD RETRO CABLE-FREE CONNECTION

In a Retro configured system the Codax Access Terminals (CAT) are not physically connected to the Codax Ticket Terminal (CTT). Each CAT is issued with a set-up code and program base number which it uses to synchronise with the CTT.

The installation example below shows a typical Retro mode connection for a Brush Wash service, a Jet Wash bay and a Vacuum bay.

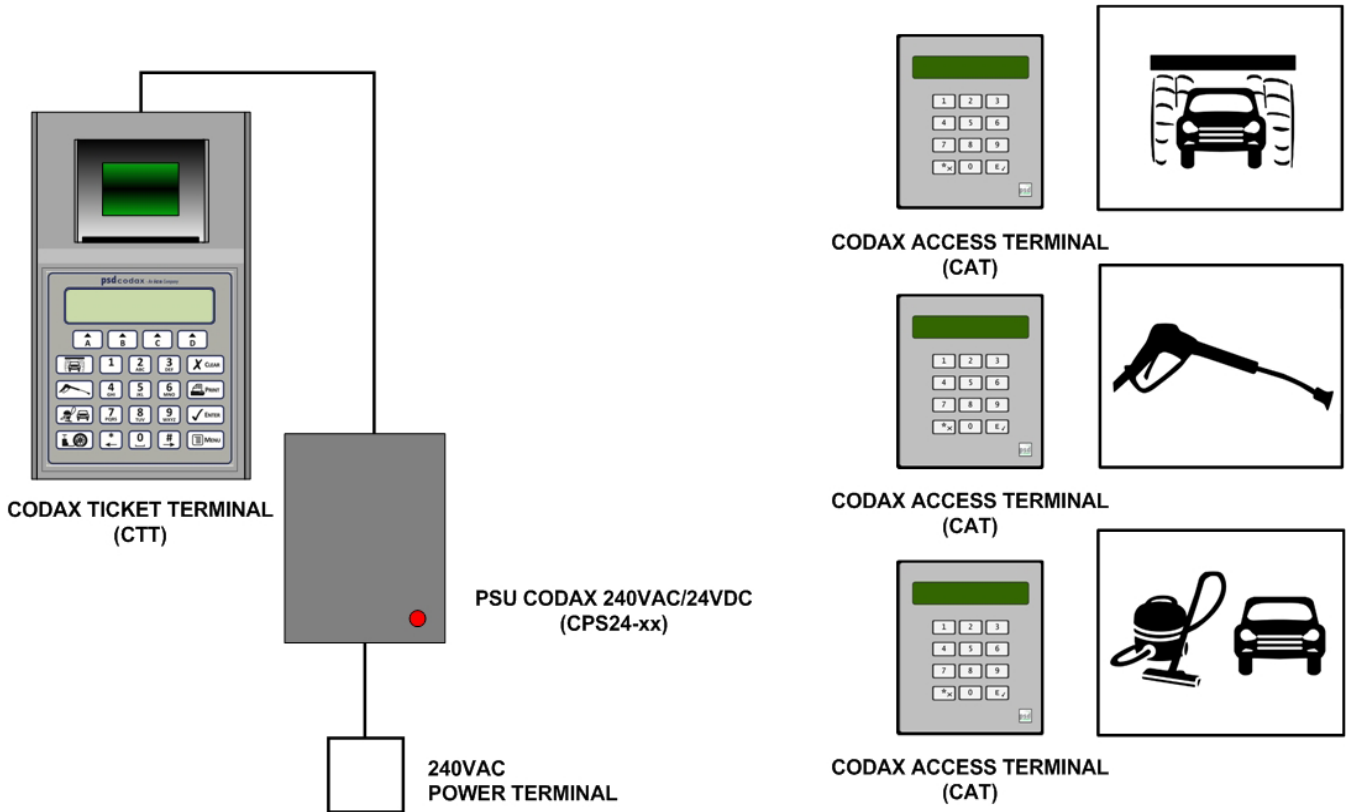

Standard Codax Installation Example for Retro Mode

CODAX ACCESS TERMINAL OWNERS MANUAL

2.4.3 DUAL TICKET TERMINAL IN AN ULTRA SYSTEM

To add a second Codax Ticket Terminal to a Codax Ultra installation, a CTT Secondary Terminal is used – CTT-S. The CTT-S connects to a standard CTT, factory configured to operate as a Primary Terminal, through the CDU via a Breakout Box – BBX-232.

The example below shows a dual CTT installation for a Brush Wash service, Jet Wash bay and Vacuum bay connected in Ultra.

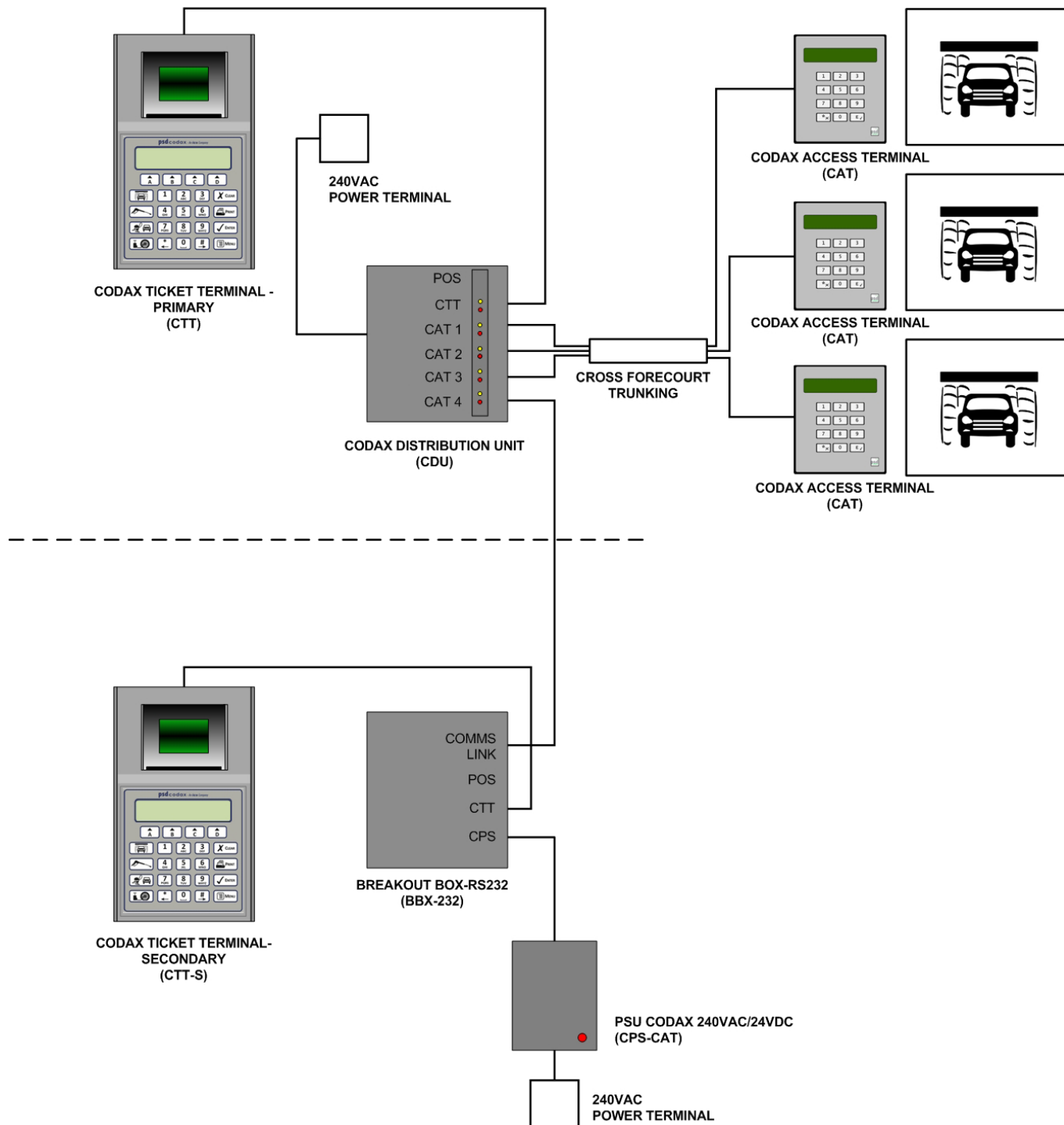

Dual Codax Ticket Terminal Installation Example for Ultra Mode

CODAX ACCESS TERMINAL OWNERS MANUAL

2.4.4 DUAL TICKET TERMINAL IN A RETRO SYSTEM

To add a second Codax Ticket Terminal to a Codax Retro installation, a CTT with an extended database range option is used – CTT-Ex. This is a software upgrade to the standard CTT to use an extended database available on purchase. Service codes issued by either CTT will be redeemed at the CATs as normal. Since there is no connection between the two CTTs there is no restriction on their placement.

The example below shows a dual CTT installation for a Brush Wash service, Jet Wash bay and Vacuum bay. Each CTT issues a set-up code and program base, both are entered at all Access Terminals.

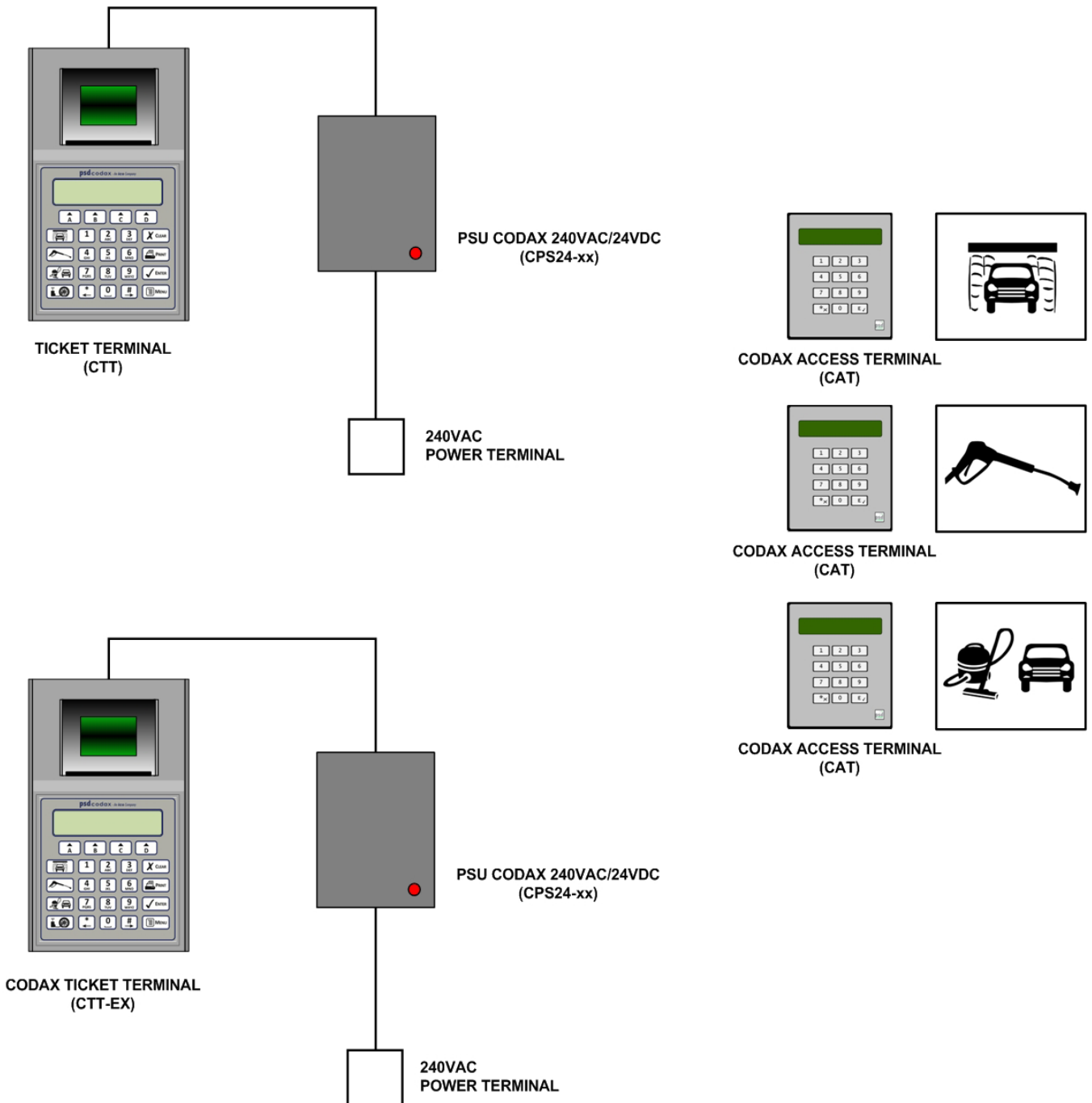

Dual Codax Ticket Terminal Installation Example for Retro Mode

CODAX ACCESS TERMINAL OWNERS MANUAL

2.4.5 DUAL RETRO CONNECTION

The Dual Retro connection refers to an installation where two wash services of the same type are available when operating in Retro mode. The example in the illustration below shows an installation with two Brush Wash machines. To allow a single Brush Wash service code ticket to be redeemed at either machine, the Dual Retro connection is required. The Dual Retro connection may operate over RS232, as in the example below, or RS485 when the Smartcard and Barcode reader options are installed. The Current Loop Driver (CLD) extends the cable range for RS232. The CAT operating in Dual Retro mode must remain synchronised at all times to prevent a fault. The CLD unit keeps the CAT powered even if the Carwash is taken off line.

Dual Retro is an optional upgrade. The Dual Retro mode may however be disabled from the set-up codes to operate standalone if required for servicing and maintenance.

The installation example below shows a typical dual Retro installation for two Brush Wash services, a Jet Wash bay and a Vacuum bay.

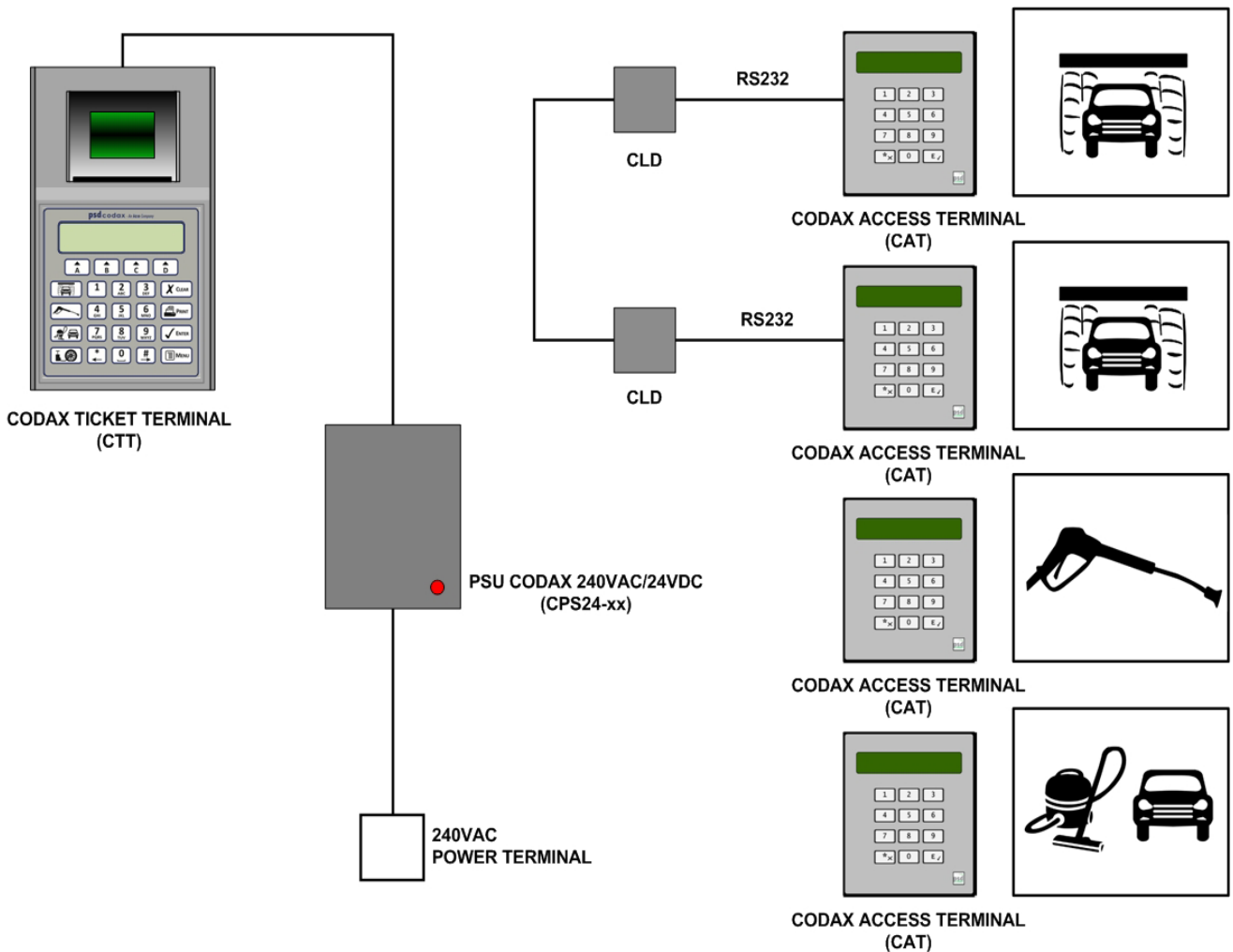

Dual Retro Installation Example

CODAX ACCESS TERMINAL OWNERS MANUAL

2.4.6 NETWORKED RETRO CONNECTION

The Networked Retro connection refers to an installation where three or more wash services of the same type are available when operating in Retro mode using the Access Network Controller (ANC). For example, this allows a single Jet Wash ticket to be redeemed at any Jet Wash bay connected to the ANC. The standard ANC allows up to eight machines to be networked, the expanded ANC allows up to sixteen.

The example below shows an installation for a Jet Wash with three bays. A Brush Wash service and Vacuum bay are also included in this installation.

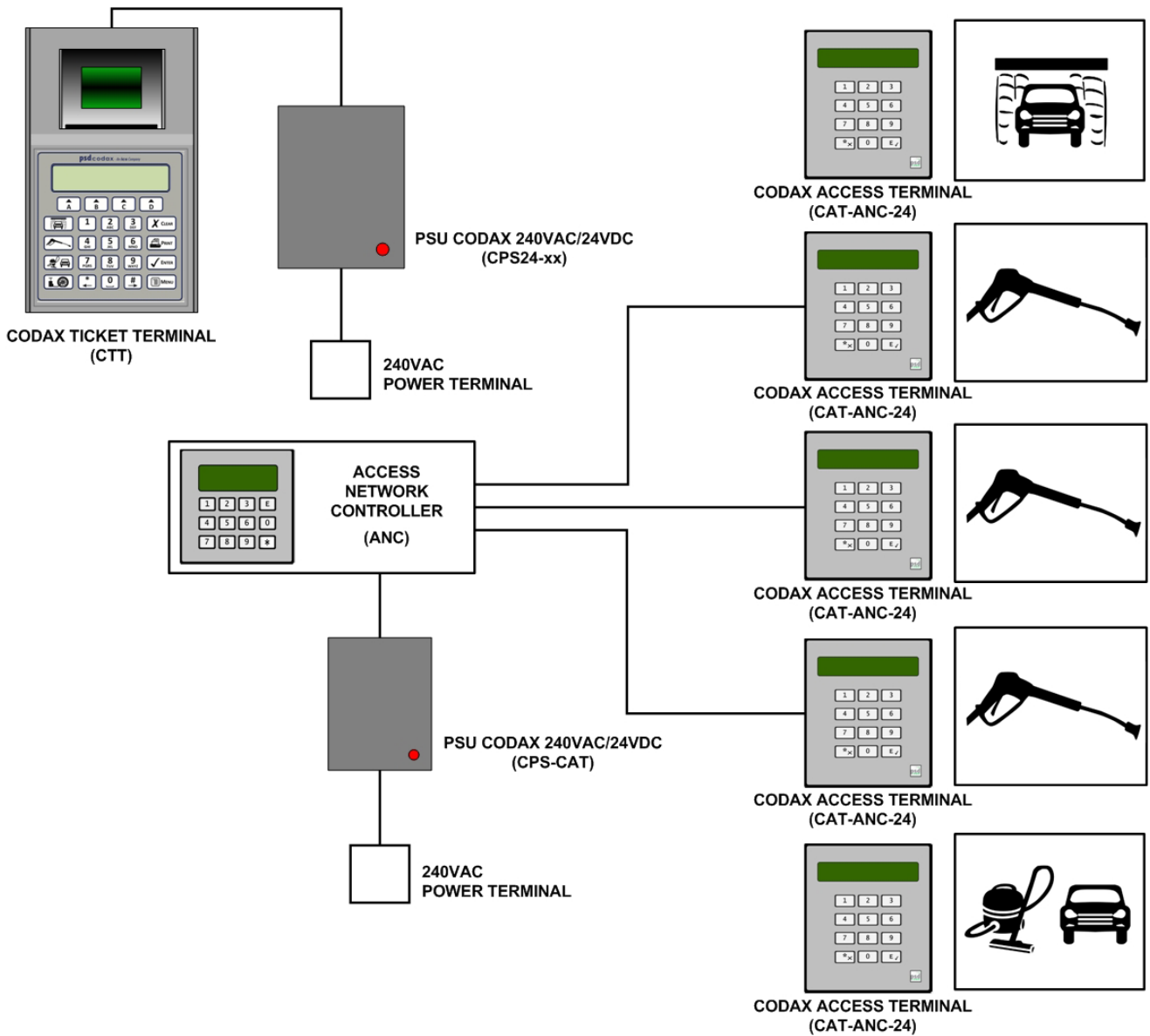

Networked Retro Installation Example

CODAX ACCESS TERMINAL OWNERS MANUAL

2.4.7 COMBINED CONNECTION

The Codax system can be expanded to meet the needs of a large forecourt installation. Mixed Ultra and Retro configurations are possible within a single installation. If the maximum number of outputs of a single CDU is exceeded, two or more can be simply linked together.

The following example illustrates a forecourt with three Brush Wash services and two Jet Wash Bays, all operating in Ultra mode. A Vacuum bay is added to the installation and operates in Retro.

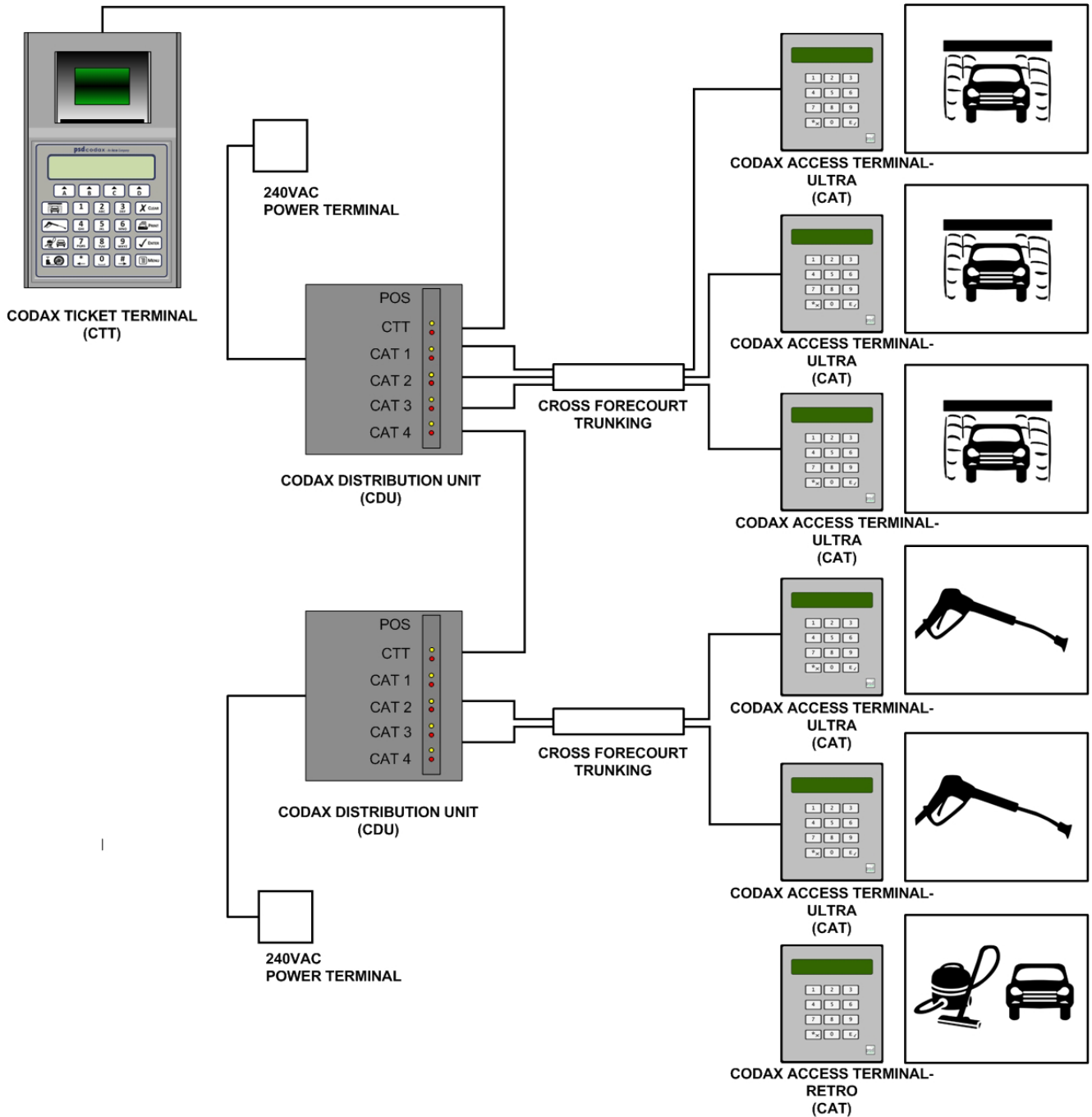

Combined Codax Installation Example

2.5 TERMINAL LAYOUT

2.5.1 ACCESS PANEL

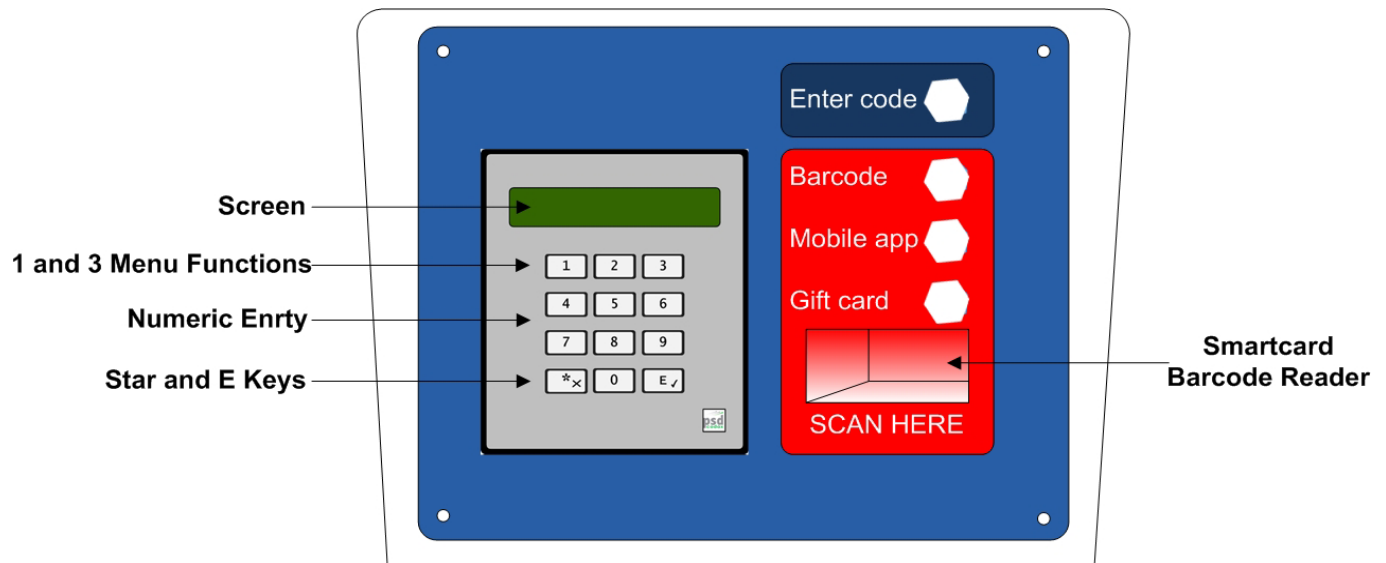

2.5.2 NUMERIC ENTRY KEY PAD



2.5.3 FUNCTION KEYS

- 1** Menu Function – Back Function
- 3** Menu Function – Next Function
- *_x** Star Key – Press and Hold to Access Setup
Exit from Setup
Cancel Entry
- E_✓** Enter Key – Accept Codes

2.6 MACHINE INSTALLATION & MAINTENANCE

2.6.1 POWERING UP THE ACCESS TERMINAL

Loading Terminal Configuration

The Terminal configuration is held in Battery Backed RAM (BB RAM). A secondary backup is stored in an E2PROM module. On power up, the integrity of the configuration in BB RAM is checked and if correct the configuration is loaded.

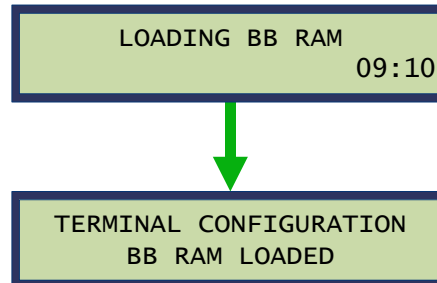

If a problem is detected in the contents of BB RAM, the integrity of the configuration in the E2PROM module is checked and if correct the configuration is loaded.

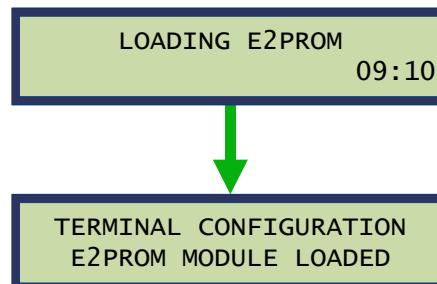

If neither of the stored configuration sources are correct, the configuration defaults are loaded. Following this the system will require a full setup.

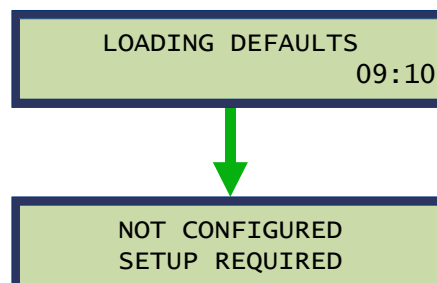

Note: An E2PROM module must be fitted to operate this equipment

CODAX ACCESS TERMINAL OWNERS MANUAL

Start-up Sequence

The start-up sequence shows the terminal configuration. Table 1 below shows the information shown during the start-up sequence

Operating Mode	Ultra	Cabled installation	
	Retro	Cable-free installation	
Machine	Brush Wash Machine type or Auxiliary		
Operating State	Normal operation		
	Machine Link Off	Machine Link is disabled – See section <i>MACHINE LINK CONTROL - 2.6.3</i>	
	Test Mode On	Initial test mode is enabled – See section <i>INITIAL TEST MODE - 2.6.2</i>	
Auxiliary Mode <i>(Auxiliary only)</i>	Timed Output		
	Pulsed Output	Mode 1 Mode 2	Binary Output
			Pulses per Program
California <i>(California only)</i>	CK38	Machine variant for California machine type	
	CK45		
PLC No #	Terminal address on the Ultra network		<i>Ultra only</i>
Program Base #	Program base offset number		<i>Retro only</i>
## Programs	Number of programs available		

Table 1 – Start-up Sequence information

Start-up Sequence example

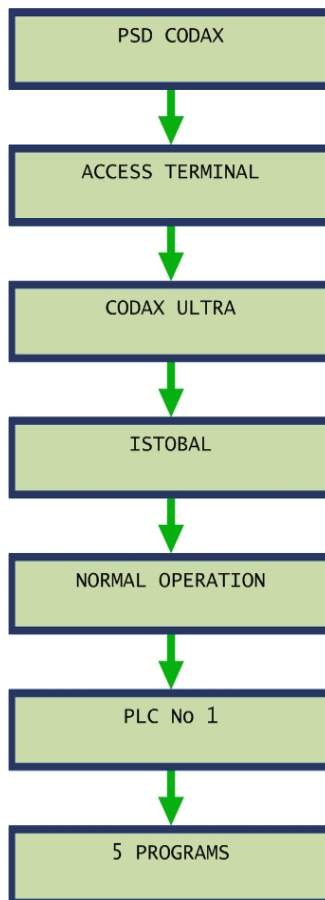

2.6.2 INITIAL TEST MODE

The initial test mode is a special test mode to aid installation available for new Codax Access Terminals only. In this mode the programs can be operated without the need for service code or test code entry and allows program numbers to be entered to start the desired program. Following installation this mode is disabled using Access Code **2369**. See section 3.1 – *Accessing System Setup on access code usage*.

Note: *Once the Initial Test Mode is disabled it can never be re-enabled.*

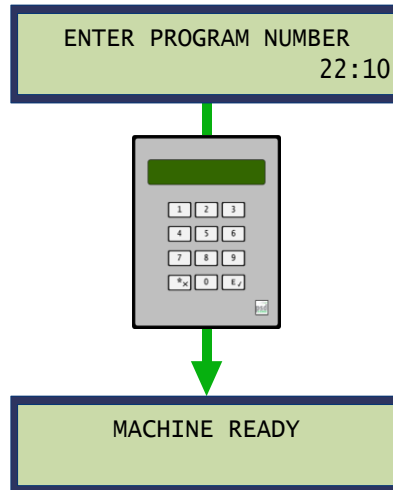

2.6.3 MACHINE LINK CONTROL

The Machine Link refers to the connection between the Codax Access Terminal (CAT) and the Car Wash Machine it controls. The Machine Link includes the program control signals output from the CAT to the machine and Machine Status and Power signals input to the CAT from the machine.

To aid installation and to test the operation of the CAT and connection to the Codax Ticket Terminal in isolation, the Machine Link may be disabled. Two Access Codes are available to enable and disable the Machine Link.

Access code **2361** Enables the Machine Link

Access code **2362** Disables the Machine Link

See section 3.3 - *ACCESS CODES*, for a full list of Access Code available.

2.6.4 MACHINE LINK SIGNALS

Table 2 below shows the Machine types supported and the Machine Link signalling details. Columns in this table contain the following information.

Machine Type

Machine manufacturer.

Machine Mode

Operational mode variations available for particular machine types.

Inputs

The Codax Access Terminal has three inputs available. Three columns show how the inputs are allocated per Machine Type and Mode.

M/C Busy Code ACK	Machine Busy signal is applied throughout the wash sequence Code Acknowledge signal is applied in acknowledgement to the program control signal.
Reset	The Reset signal is applied at the end of the wash to indicate completion. Reset High and Reset Low indicates the active state of the Reset signal.
Vehicle in M/C Frost Shut	Vehicle in Machine signal Frost Shutdown signal indicates the machine has shutdown to prevent damage due to extreme low temperatures.
M/C Present	Machine Present is a continuous signal from the machine to indicate it is operational. A fault code is reported immediately if this signal is lost.

Note: Machine type Washtec Softcare does not provide conventional control signals and instead provides three machine condition signals.

Outputs

Six output signals are available at the CAT. These are normally used for program selection, but for certain machine types some outputs are used for pre-wash and door control signals.

Binary Binary+ Custom	Program selection is made through a binary coded representation As Binary with additional coding Program selection is made through a custom pattern set by user
-----------------------------	---

Output Control

This defines how the program output signals are applied.

Hold	The program signal is held until the machine is busy, the signal is acknowledged or the machine reset.
Pulse	A pulse is applied at the start of the wash
Busy	The program's signal is held until the machine is busy
ACK	The program's signal acknowledged by the machine
Reset	The program's signal is held until the Reset signal is received

CODAX ACCESS TERMINAL OWNERS MANUAL

2.7 MACHINE LINK CONTROL

2.7.1 E2PROM MACHINE TABLE

Machine		Inputs			Outputs						Output Control			
Type	Mode	1	2	3	1	2	3	4	5	6	Hold	Pulse	Ack	Reset
Istobal	Euro	Code Ack	Vehicle in M/C	M/C Present	Program			x	Pre Wash				▪	
	UK	Code Ack	x	M/C Present	Program			Door	Pre Wash				▪	
Wesumat Manual		Vehicle Detect	M/C Busy	M/C Present	Program							▪		
California	CK45	x	Code Ack	M/C Present	Program								▪	
	CK38	x	M/C Busy	M/C Present	Program								▪	
Washtec Softcare		M/C Input 1	M/C Input 2	M/C Input 3	Program			x					▪	
Ceccato	Euro	Vehicle In M/C	Code Ack	M/C Present	Program						▪	▪		
	UK	x	Code Ack	M/C Present	Program						▪	▪		
Christ		x	M/C Busy	M/C Present	Program								▪	
Karcher	Busy	Frost Shut	M/C Busy	M/C Present	Program						▪	▪		
	Code Ack	Frost Shut	Code Ack	M/C Present	Program								▪	
Tammermatic	T700 Ultralux	Reset	x	M/C Present	Program									▪
	Ultra	Reset	Vehicle in M/C	M/C Present	Program									▪
Aquarama	Euro	Code Ack	Vehicle in M/C	M/C Present	Program	x		x					▪	
	UK	Code Ack	Vehicle In M/C	M/C Present	Program								▪	
Ryko Italian	Euro Busy	M/C Busy	Vehicle In M/C	M/C Present	Program						▪	▪		
	Euro Reset	Reset	Vehicle In M/C	M/C Present	Program							▪		▪
	UK Busy	M/C Busy	x	M/C Present	Program						▪	▪		
	UK Reset	Reset	x	M/C Present	Program							▪		▪
Ryko USA		Reset Low	Reset High	M/C Present	Program						▪	▪		
Autoequip	Busy	M/C Busy	x	M/C Present	Program						▪	▪		
	Reset	Reset	x	M/C Present	Program							▪		▪
PDQ	Busy	x	M/C Busy	M/C Present	Program						▪	▪		
	Code Ack	x	Code Ack	M/C Present	Program								▪	
Wash World Razor	Busy	M/C Busy	x	M/C Present	Program						▪	▪		
	Reset	Reset	x	M/C Present	Program							▪		▪

CODAX ACCESS TERMINAL OWNERS MANUAL

Machine		Inputs			Outputs						Output Control			
Type	Mode	1	2	3	1	2	3	4	5	6	Hold	Pulse	ACK	Reset
Leisu Wash		x	M/C Busy	M/C Present	Binary/1of6/Custom							▪	▪	
Atlantis		x	Code ACK	M/C Present	Binary/Custom						▪			▪
Belanger		x	M/C Busy	M/C Present	Binary/1of6/Custom						▪		▪	
Jim Coleman		x	M/C Busy	M/C Present	Binary/1of6/Custom							▪	▪	
Megatechnics		Vehicle in M/C	Code ACK	M/C Present	Binary/1of6/Custom						▪			▪
Mark VII		Code ACK	x	M/C Present	Binary/Custom						▪			▪
Hanna Conveyor		x	x	x	Binary/Custom				Start		▪			
Conveyor		x	x	M/C Present	Binary/Custom							▪		

2.7.2 AUXILIARY TABLE (JET WASH, VACUUM AND AIR)

Machine		Inputs			Outputs						Output Control				
Type	Mode	1	2	3	1	2	3	4	5	6	Hold	Pulse	Busy	Ack	Reset
Auxiliary Timed		x	x	M/C Present	ON		x	x	x	x	▪				
Auxiliary Pulsed	Mode 1	x	x	M/C Present	Binary/Custom							▪			
	Mode 2	M/C Busy	x	M/C Present	Binary/Custom							▪	▪		

2.7.3 MACHINE TEST TICKETS

Test Tickets are available from the Codax Ticket Terminal (CTT) for issue to the site Engineer for maintenance purposes.

Test Sessions

A Test Session is started when a Test Ticket is issued from the CTT. The time and date the session is started is recorded by the CTT. A number of test washes may then be performed at the machine requiring maintenance. On completion the Test Session is closed at the CTT and a Test Report is printed – One copy for the Site Engineer and one copy for the Site Operator. All Test Sessions and Test Washes are recorded by the CTT and details are printed on Shift and Audit Reports.

The number of washes available on a single Test Ticket is limited and dependant on the machine operating mode. If more washes are required, any number of Test Tickets may be issued for a single Test Session.

Ultra Mode Test Tickets

Forecourt services connected in Ultra mode are serviced from a single Test Ticket for Ultra systems. The ticket can be used up to 15 times on any machine connected via the Ultra network. The Ticket Terminal will log uses for each machine and include this as part of the Site and Audit reports.

Retro Test Tickets

A Test Ticket for Retro installations is machine specific. A maximum number of 5 test washes may be performed on a single test ticket.

CODAX ACCESS TERMINAL OWNERS MANUAL

2.7.4 TEST TICKET LAYOUTS

Ultra Systems

The Test Ticket for Ultra systems has the following layout:

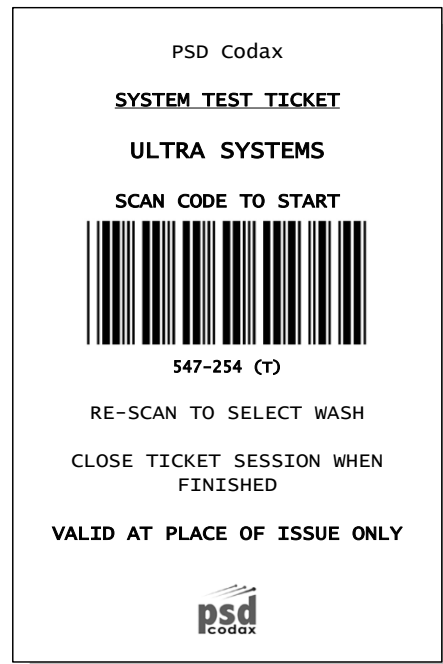
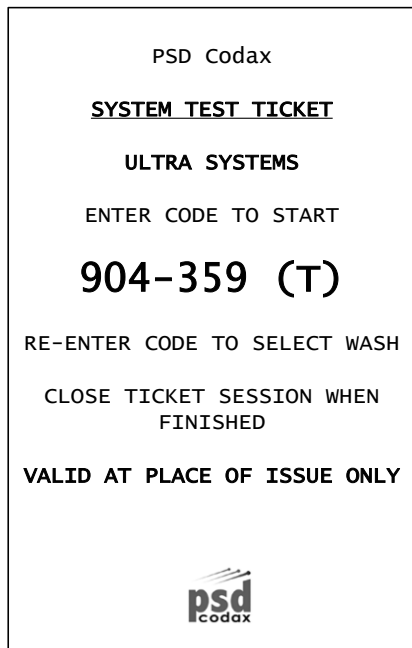

Retro Systems

The Test Ticket for Retro systems has the following layout:

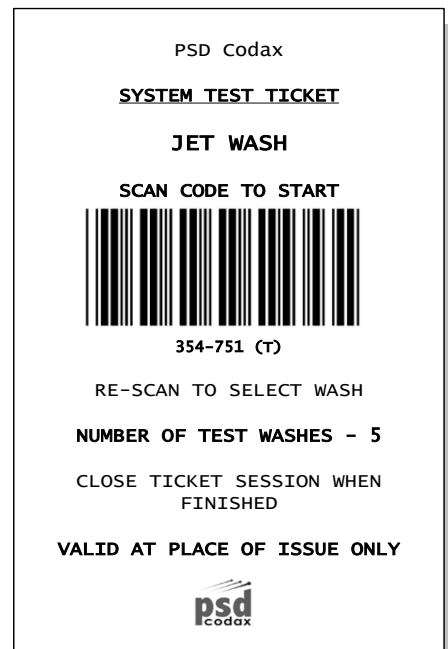
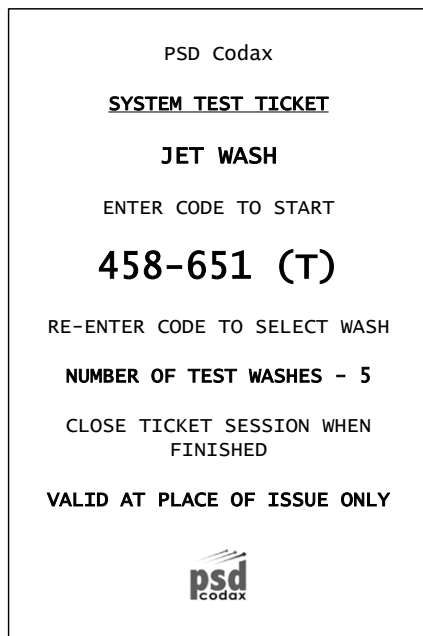

2.7.5 Test Wash Operational Sequence

Ultra Systems

On initial entry of a valid Test Ticket code (*Keyed or Scanned*), Test Mode is entered and a new Test Session started. To select a wash program the Test Ticket code is re-entered (*Keyed or Scanned*) and the wash program selected by entering a wash program number.

For additional test washes the Test Ticket code is re-entered and a new wash program selected. This may be repeated for the life of the Test Ticket. If a new Test Ticket is issued any remaining washes on an old ticket are cancelled.

See section *MACHINE RUNNING SEQUENCES – 5.5* for wash sequence variations.

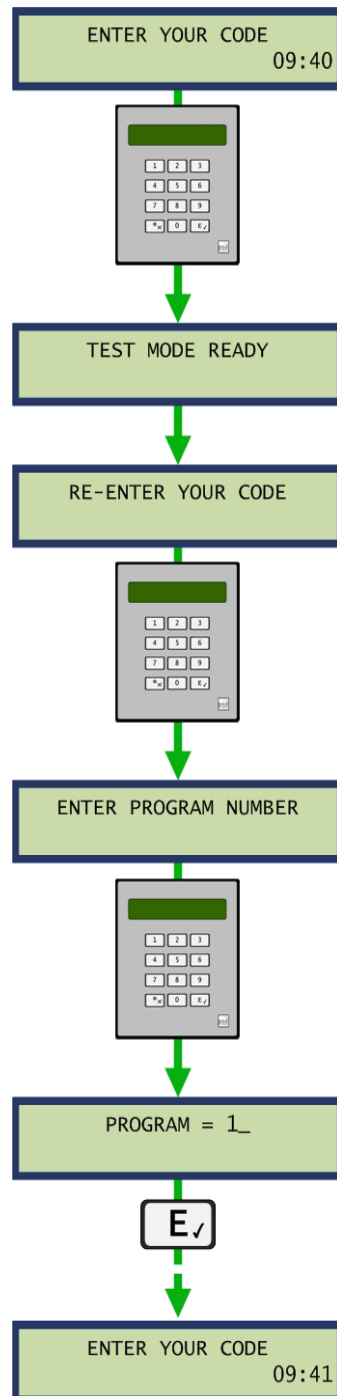

CODAX ACCESS TERMINAL OWNERS MANUAL

Retro Systems

On entry of the Test Ticket code (*Keyed or Scanned*) the remaining number of washes available on that ticket is shown before the operator is invited to select a test program number. The wash program may then be selected by entering a wash program number.

For additional test washes the Test Ticket code is re-entered and a new wash program selected. This may be repeated for the life of the Test Ticket. If a new Test Ticket is issued and used any remaining washes on an old ticket are cancelled.

See section 5.5 - *MACHINE RUNNING SEQUENCES* - for wash sequence variations.

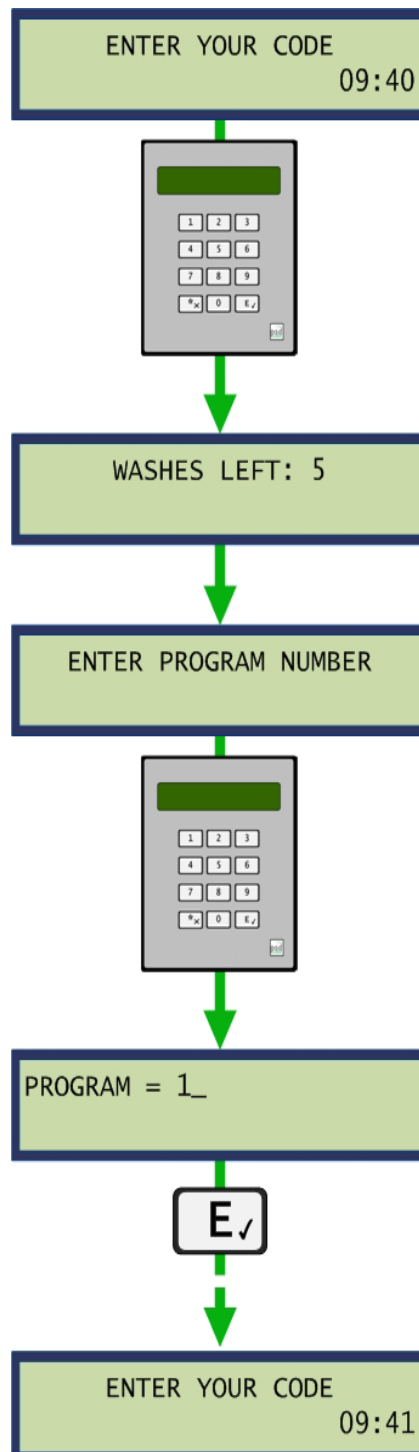

3 TERMINAL CONFIGURATION

3.1 ACCESSING SYSTEM SETUP

System setup functions are available through the special Access Codes. These codes are entered by pressing and holding the *_x key for a few seconds.

Access Codes are normally four digits in length. However a special User Setup menu is available by entering the five-digit Engineer's password. This menu allows a number of setup functions to be accessed. A number of functions available in the Setup Menu are also available individually using a four-digit Access Code. See section 3.3 - ACCESS CODES, for a complete list of four-digit codes available.

Engineering password: 32923

The following illustration shows how the setup menu and access codes are entered.

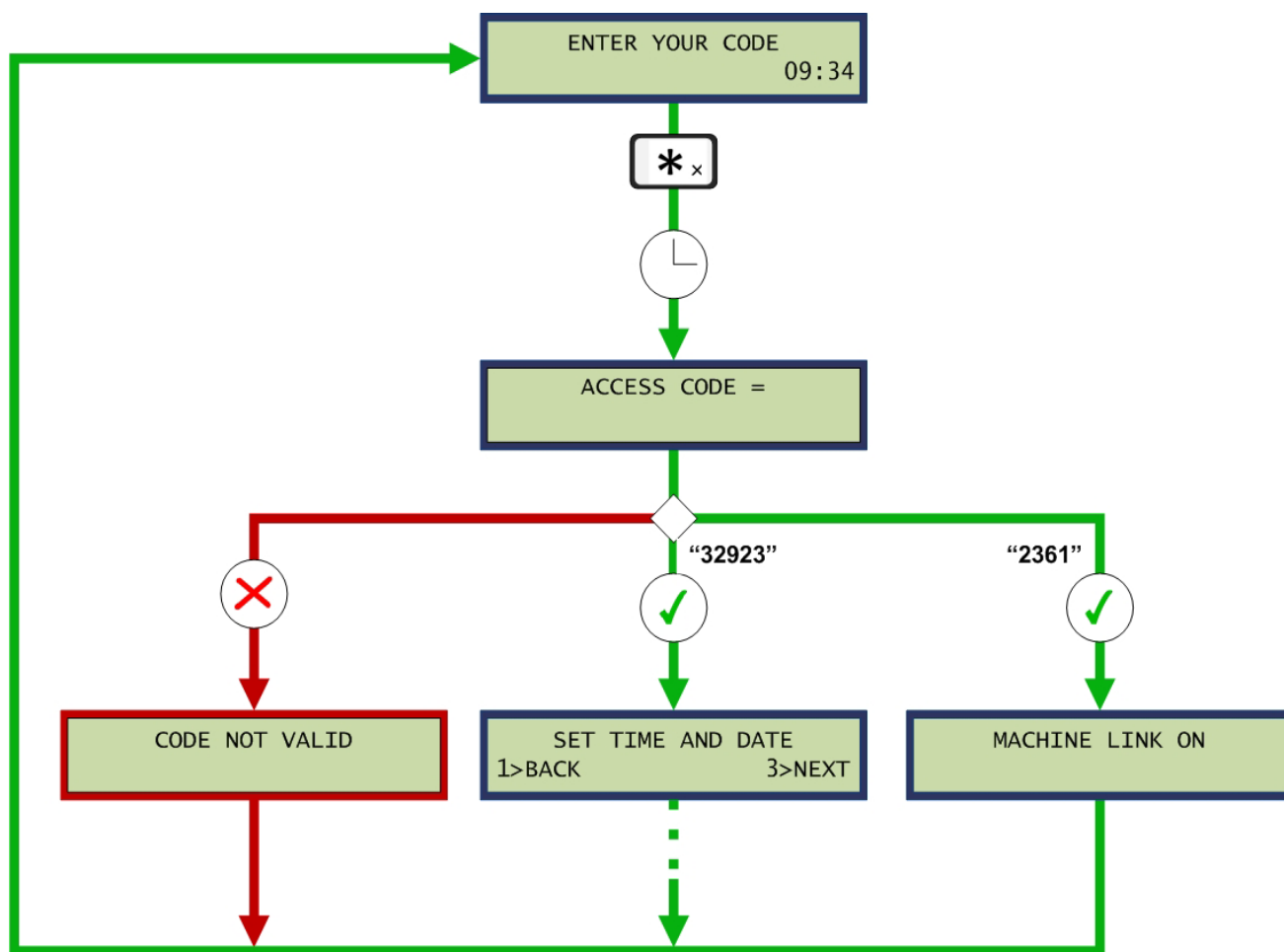

3.2 USER SETUP MENU

The user setup menu allows a number of setup functions to be accessed in the form of a menu using a single five digit access code. See illustration above.

3.2.1 SETUP OPTIONS

Note: Light Blue indicates either an Optional Upgrade or a Retro Only Function

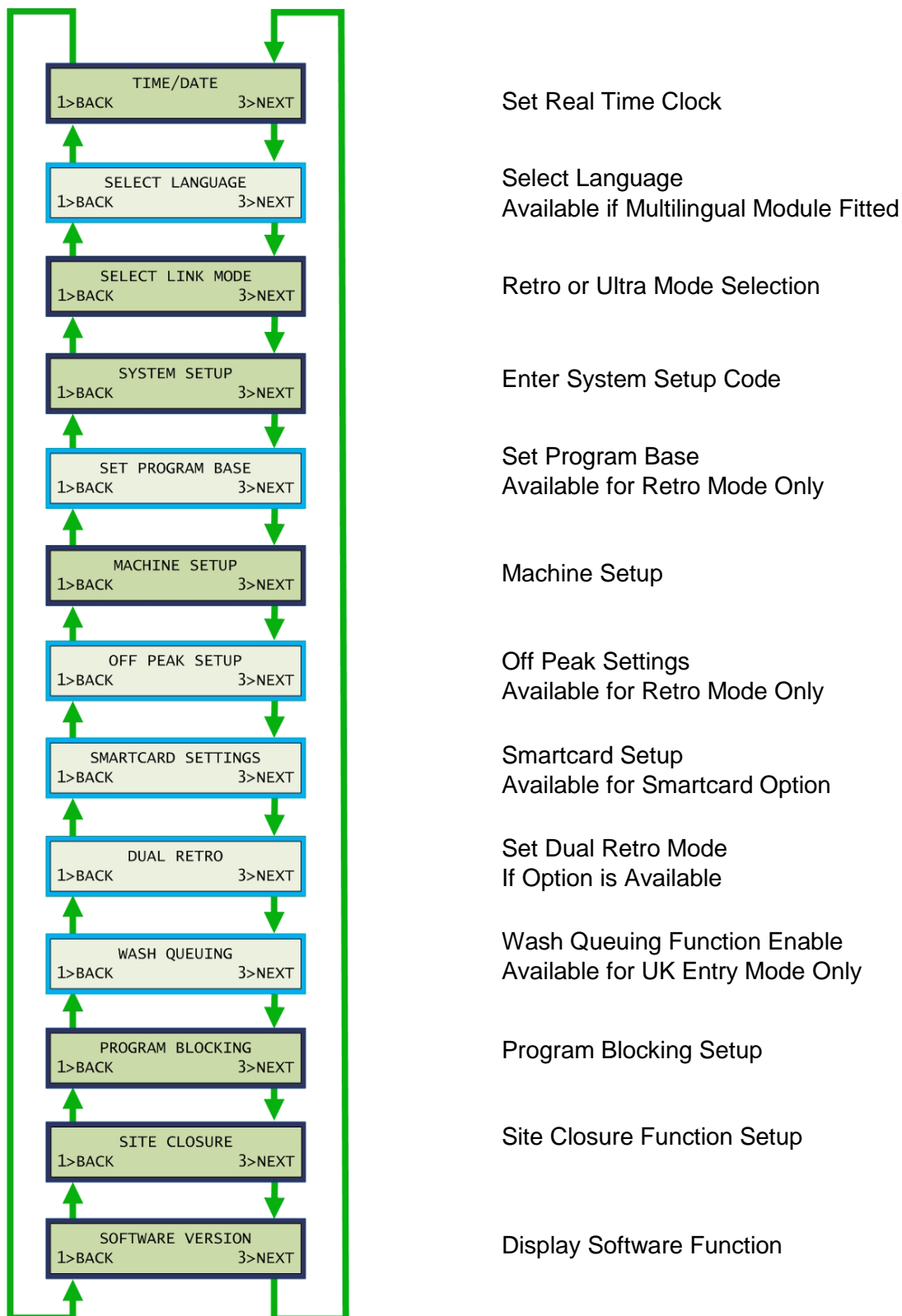

CODAX ACCESS TERMINAL OWNERS MANUAL

3.2.2 SET TIME AND DATE

The *Set Time and Date* function allows the current time and date to be adjusted. Date and Time is entered in the order: *Year/Month/Day/Hour/Minute*. Times are entered in 24 hour format. The automatic daylight saving zone may be selected or turned off. The following zones are included:

OFF	No daylight saving adjustment
WET	Western European Time
CET	Central European Time
EET	Eastern European Time
USA	United States of America
AUS	Australia
NZL	New Zealand

Access code **2222** may also be used to adjust time and date.

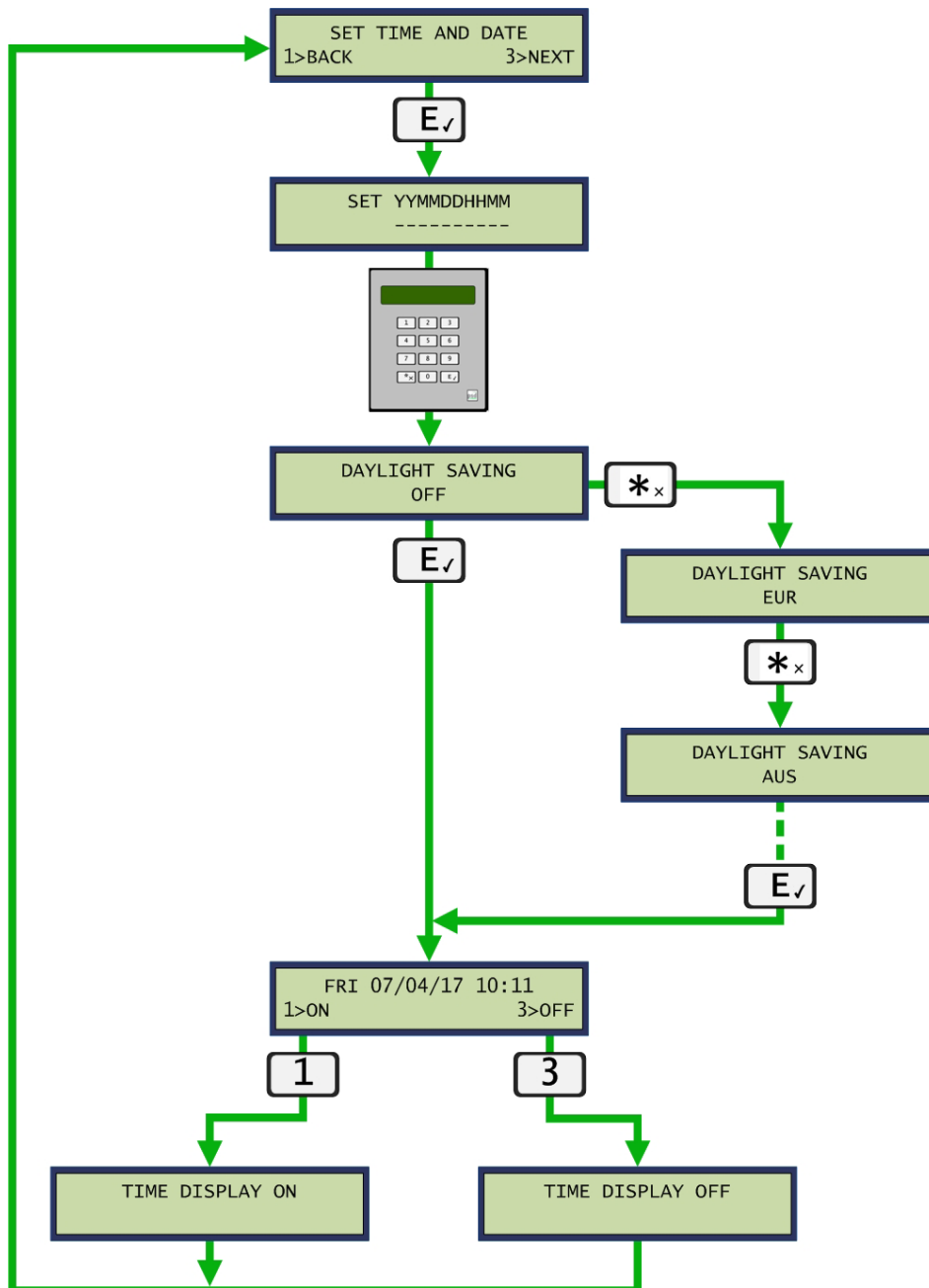

CODAX ACCESS TERMINAL OWNERS MANUAL

3.2.3 SELECT LANGUAGE (OPTIONAL UPGRADE)

The *Select Language* function allows the language for which all on screen messages and printed tickets uses. Language variations are contained in the removable E2PROM module and are factory defined. Languages available vary and are based on geographical regions.

Access Code **6728** may also be used to change the language setting.

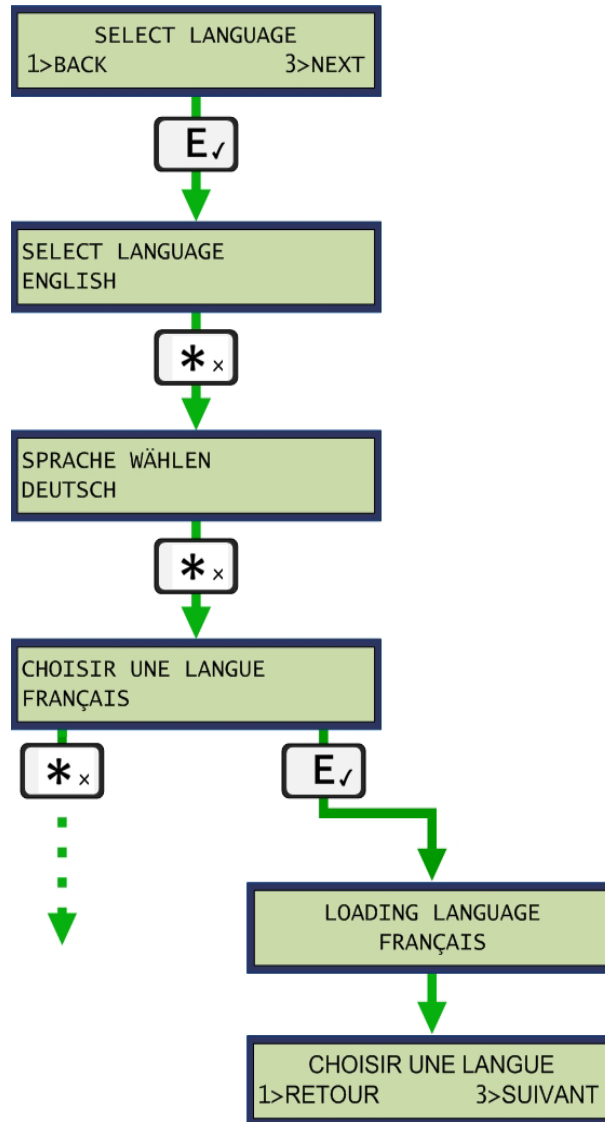

CODAX ACCESS TERMINAL OWNERS MANUAL

3.2.4 SELECT LINK MODE

The Select Link Mode function determines whether the Codax Access Terminal is operating in Retro (Cable-Free) or Ultra (Cabled) mode. See section - 2.4 INSTALLATION EXAMPLES - for installation examples.

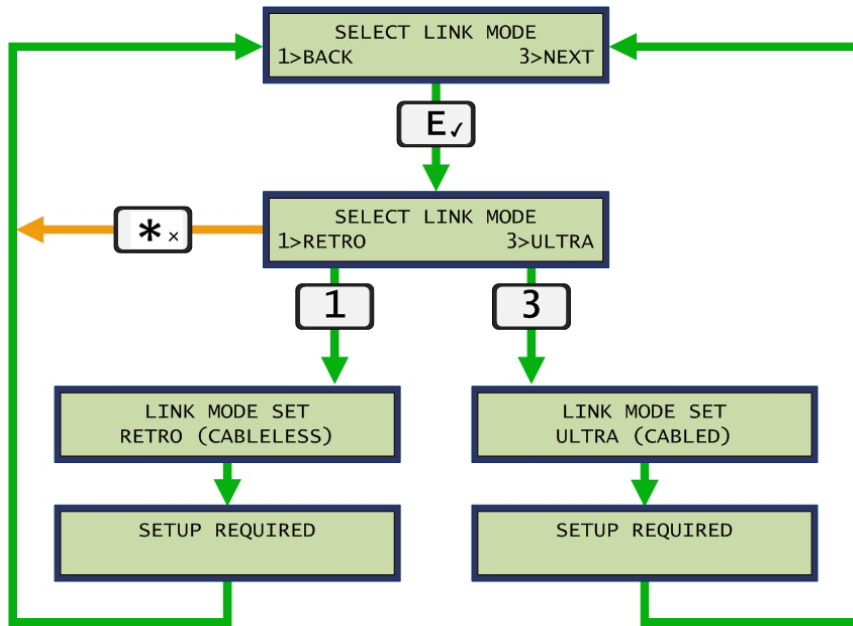

RETRO (CABLE FREE)



CODAX TICKET TERMINAL (CTT)

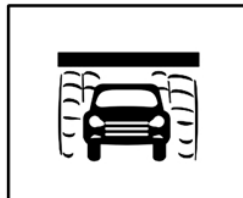

CODAX ACCESS TERMINAL (CAT)

ULTRA (CABLED)



CODAX TICKET TERMINAL (CTT)

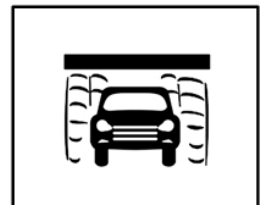
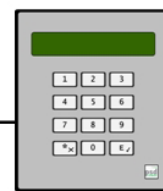

CODAX ACCESS TERMINAL (CAT)

CODAX ACCESS TERMINAL OWNERS MANUAL

3.2.5 SYSTEM SETUP

The *System Setup* function synchronises the Codax Access Terminal to the Codax Ticket Terminal. On performing a Cold Start at the Ticket Terminal, a *System Configuration* ticket containing setup codes for all initialised peripherals is printed. The respective six-digit setup codes are then entered at all Access Terminal using the *System Setup* function. In addition,

Access Code **2364** may also be used to access the *System Setup* function.

The example below illustrates the system setup process for Brush Wash service.

PSD Codax			
SYSTEM CONFIGURATION			
INITIALISED PERIPHERALS			
BRUSH WASH			
*	NORM.	PROMO.	O/PEAK
1	0.00	0.00	0.00
2	0.00	0.00	0.00
3	0.00	0.00	0.00
4	0.00	0.00	0.00
SET-UP CODE - 248-533			
JET WASH			
*	NORM.	PROMO.	O/PEAK
1	0.00	0.00	0.00
2	0.00	0.00	0.00
SET-UP CODE - 276-482			
VACUUM			
*	NORM.	PROMO.	O/PEAK
1	0.00	0.00	0.00
SET-UP CODE - 276-529			
PROGRAM BASE = 7			
SYSTEM ENABLED FOR MULTI-USE			
VALID AT THIS SITE ONLY [00]			

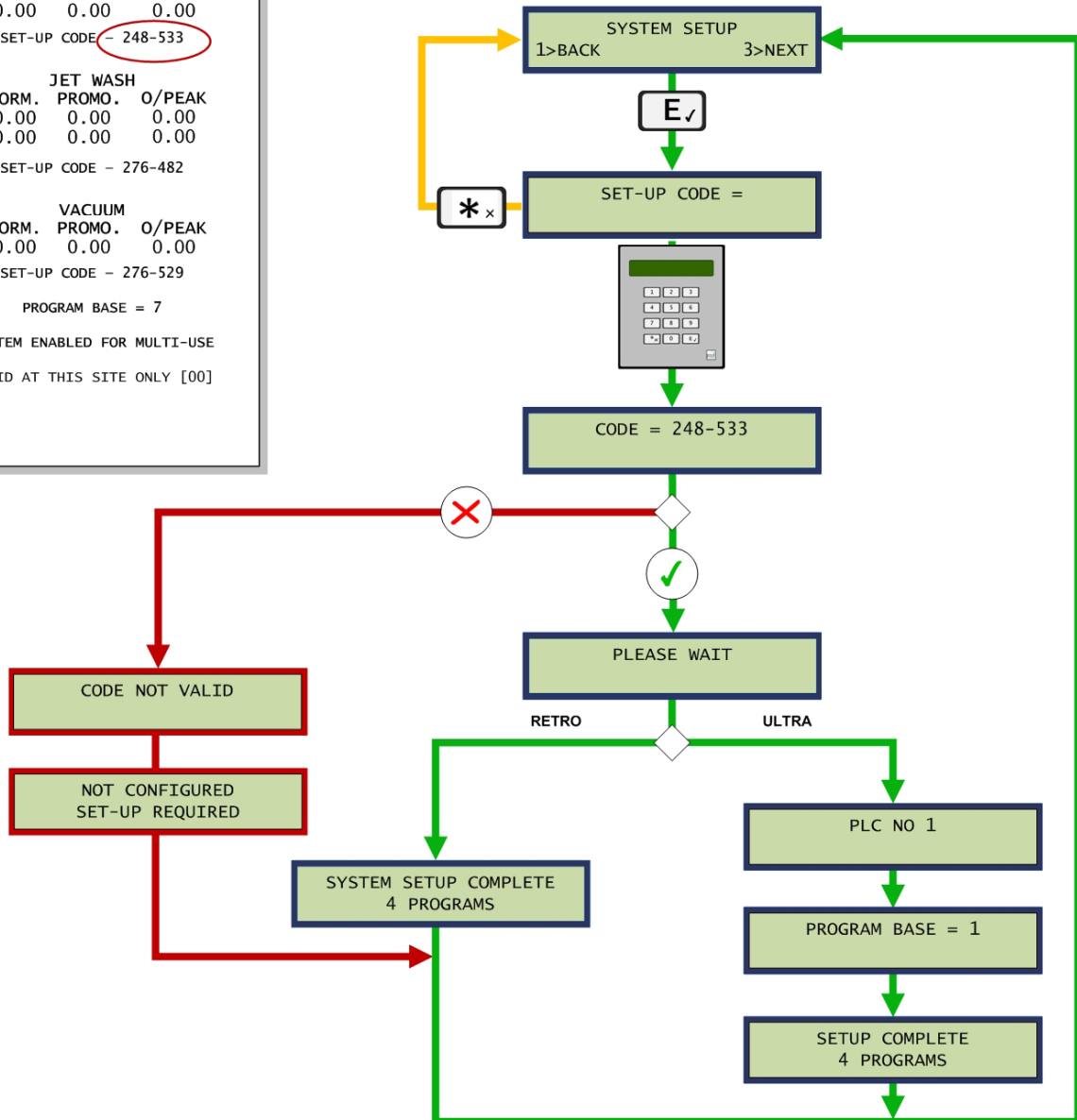

CODAX ACCESS TERMINAL OWNERS MANUAL

3.2.6 SET PROGRAM BASE (RETRO ONLY)

The *Set Program Base* function is part of the system synchronisation process for Retro configured installations. The number is taken from the *System Configuration* ticket printed by the Codax Ticket Terminal during the Cold Start configuration process.

Access Code **2364** may also be used to access the *Set Program Base* function.

The example below illustrates the system setup process for the Vacuum service from the example System Configuration ticket.

PSD Codax			
<u>SYSTEM CONFIGURATION</u>			
INITIALISED PERIPHERALS			
BRUSH WASH			
*	NORM.	PROMO.	O/PEAK
1	0.00	0.00	0.00
2	0.00	0.00	0.00
3	0.00	0.00	0.00
4	0.00	0.00	0.00
SET-UP CODE - 248-533			
JET WASH			
*	NORM.	PROMO.	O/PEAK
1	0.00	0.00	0.00
2	0.00	0.00	0.00
SET-UP CODE - 276-482			
VACUUM			
*	NORM.	PROMO.	O/PEAK
1	0.00	0.00	0.00
SET-UP CODE - 276-529			
PROGRAM BASE = 7			
SYSTEM ENABLED FOR MULTI-USE			
VALID AT THIS SITE ONLY [00]			

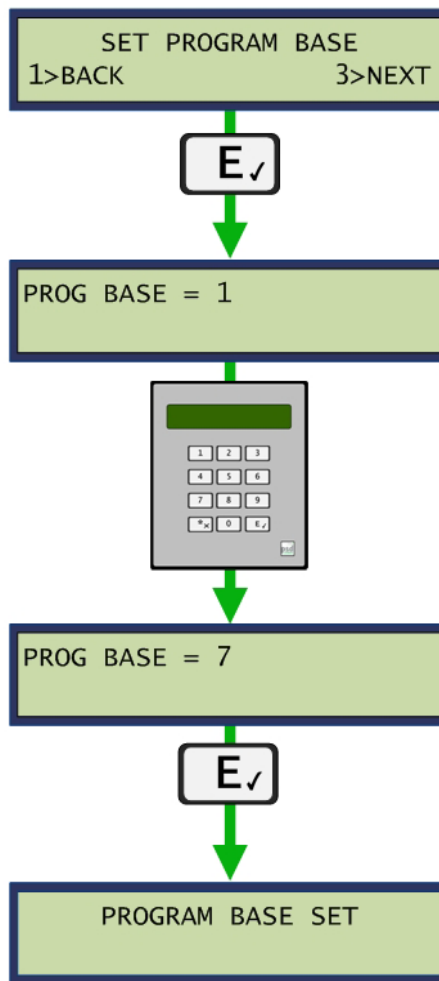

CODAX ACCESS TERMINAL OWNERS MANUAL

3.2.7 MACHINE SETUP

The machine type operated by this terminal is fixed at the factory. Certain machine mode and control options are available to the user and may be adjusted here. See *section 4 - MACHINE SETUP*.

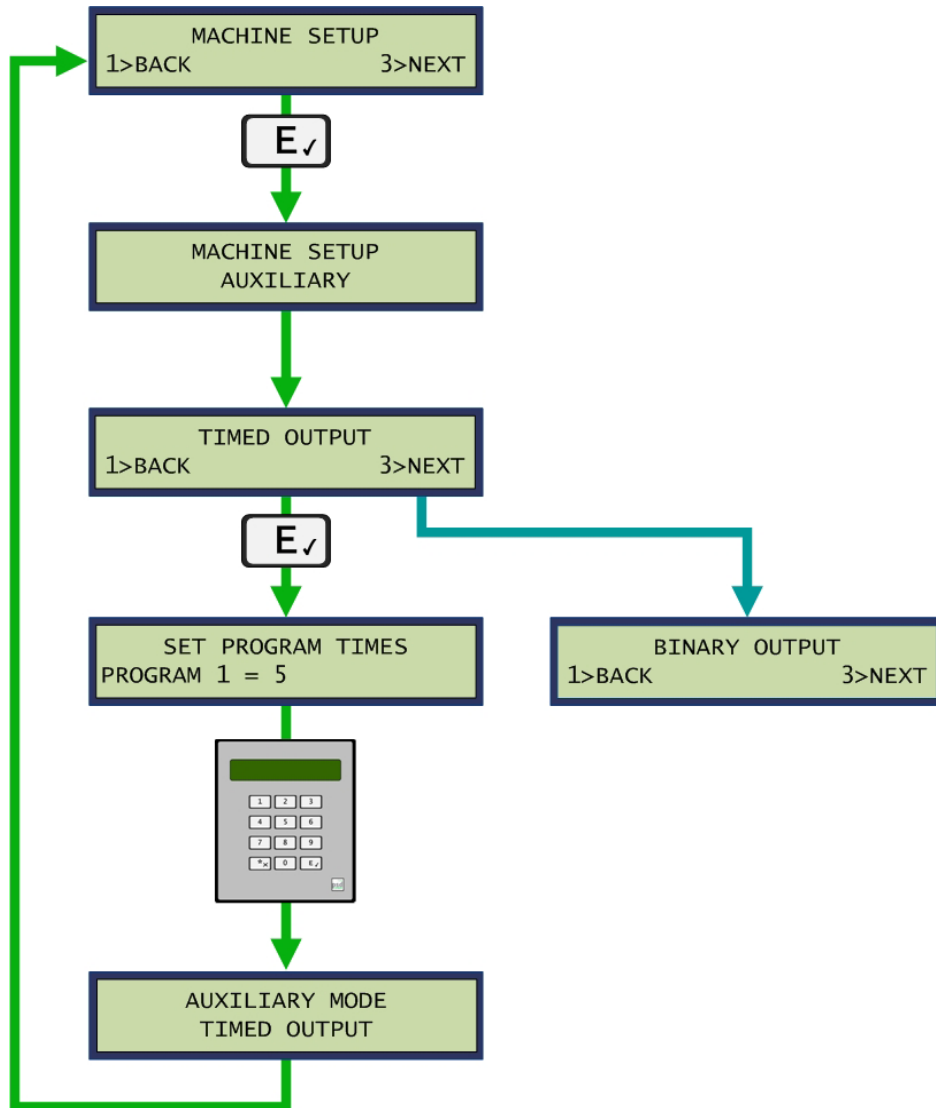

CODAX ACCESS TERMINAL OWNERS MANUAL

3.2.8 OFF PEAK SETUP (RETRO ONLY)

The *Off-Peak Setup* function is available for Retro installations only to support off-peak promotions available at the Codax Ticket Terminal (CTT). Here the start and end times of the off-peak period are defined as well as the days of the when the offer is valid. To disable the feature ensure all days are marked as *OFF*. See section - 5.1.4 OFF-PEAK CODES.

Note: For Ultra installations Off-Peak is defined at the CTT. For mixed Retro/Ultra installations, Off-Peak time settings for the Codax Access Terminal need to match the setting for CTT.

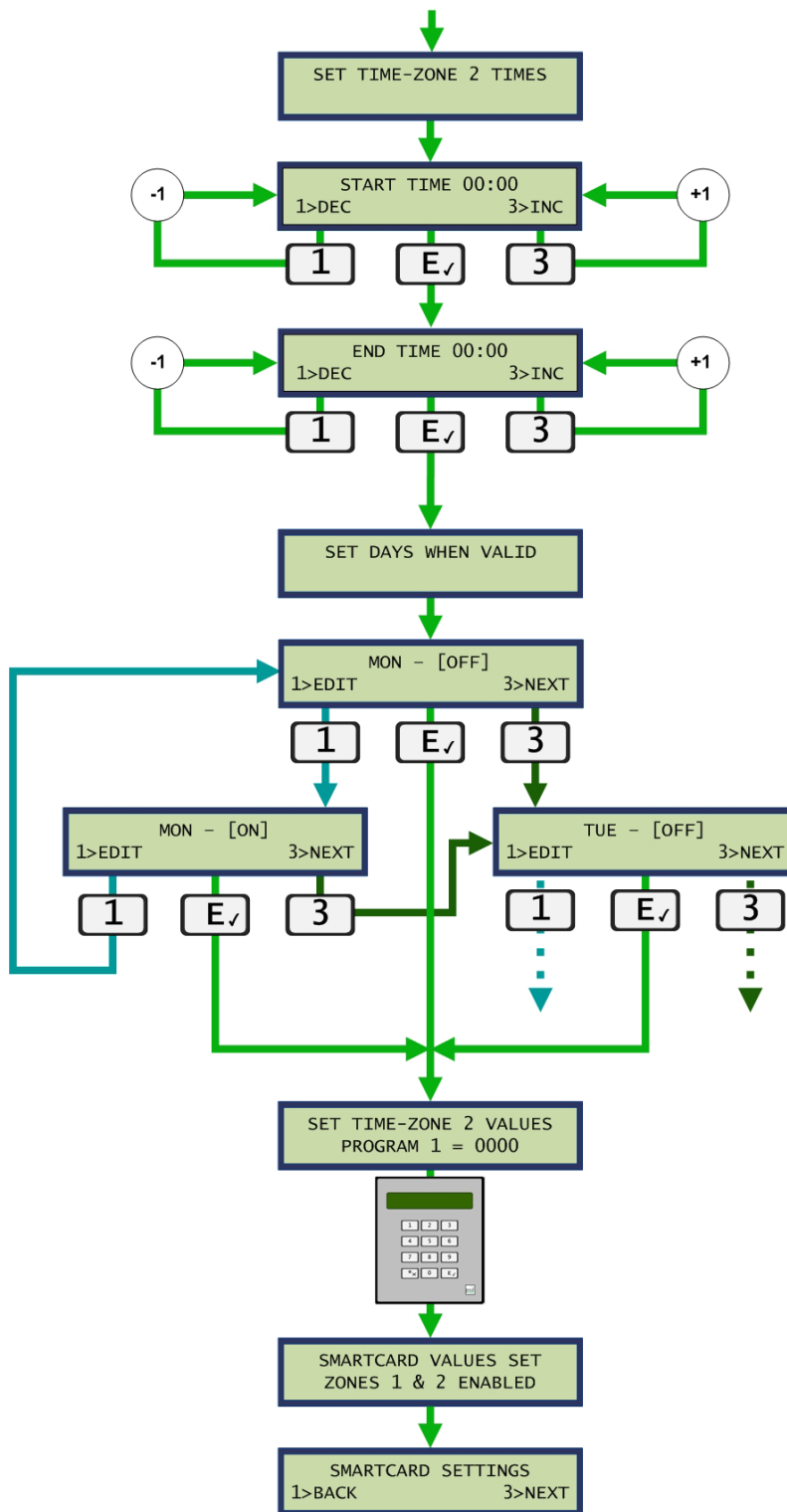

CODAX ACCESS TERMINAL OWNERS MANUAL

3.2.9 SMARTCARD SETTINGS (OPTIONAL UPGRADE)

The *Smartcard Setting* option is only able if the Smartcard option is included. The *Smartcard Setting* function allows programs to have a credit value assigned. This credit value is removed from the Value card when making a purchase. Two separate time-zones are supported to allow Smartcard promotions to match Ticket Off-peak promotions if required, The Admin card is required to make these changes.

Smartcard is available for Access Terminals purchased with either of the following upgrade options:

SCU-CAT Smartcard Upgrade for CAT

Contact PSD Codax to upgrade an existing installation to Smartcard operation.

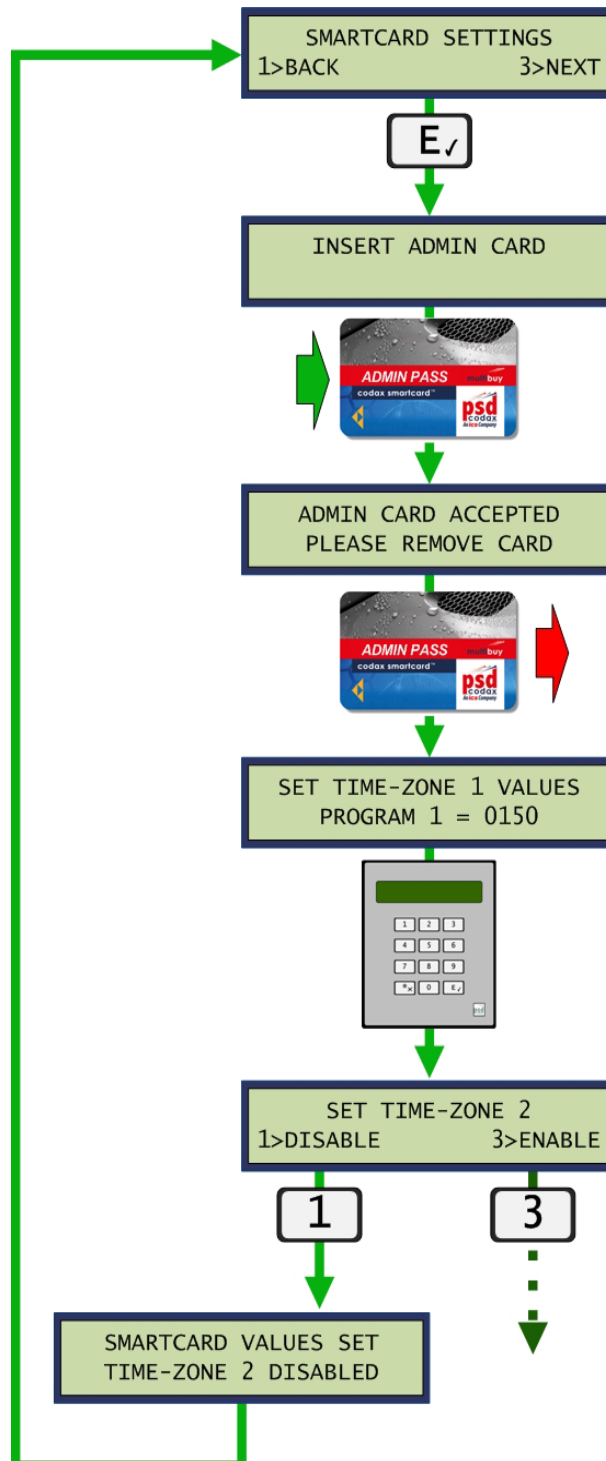

CODAX ACCESS TERMINAL OWNERS MANUAL

If the second time-zone is enabled, the times are specified from a start and end time, as well as the days of the week. Credit values for each program are also entered.

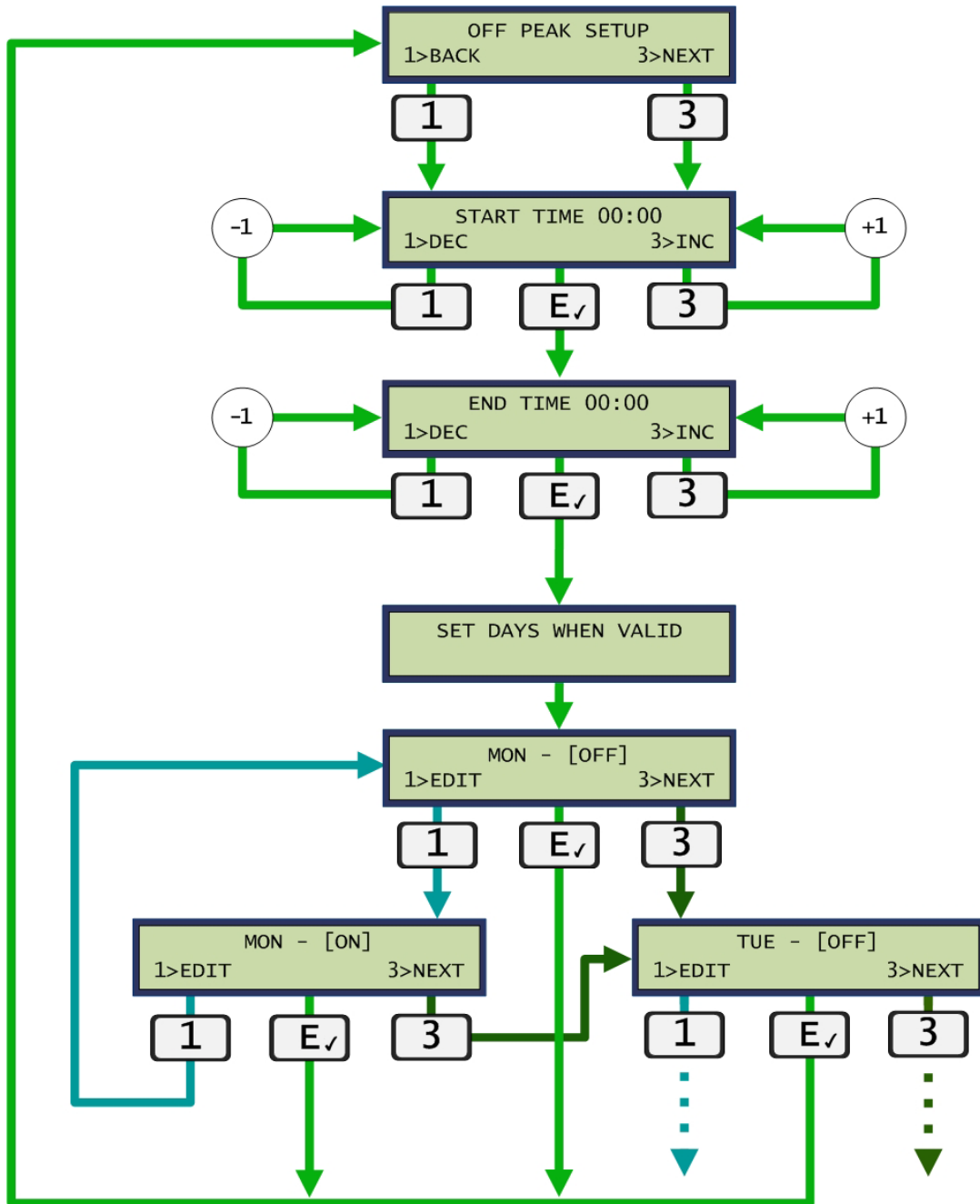

CODAX ACCESS TERMINAL OWNERS MANUAL

3.2.10 DUAL RETRO (OPTIONAL UPGRADE)

The *Dual Retro* option is only available if the Dual-Retro option is included. The *Dual Retro* function allows the feature to be enabled or disabled to allow the Access Terminal to work in isolation during installation and maintenance.

Dual Retro is available for Access Terminals purchased with either of the following upgrade options:

- DRK-232 Dual Retro Kit for RS232
- DRK-485 Dual Retro Kit for RS485

Contact PSD Codax to upgrade an existing installation to Dual Retro operation.

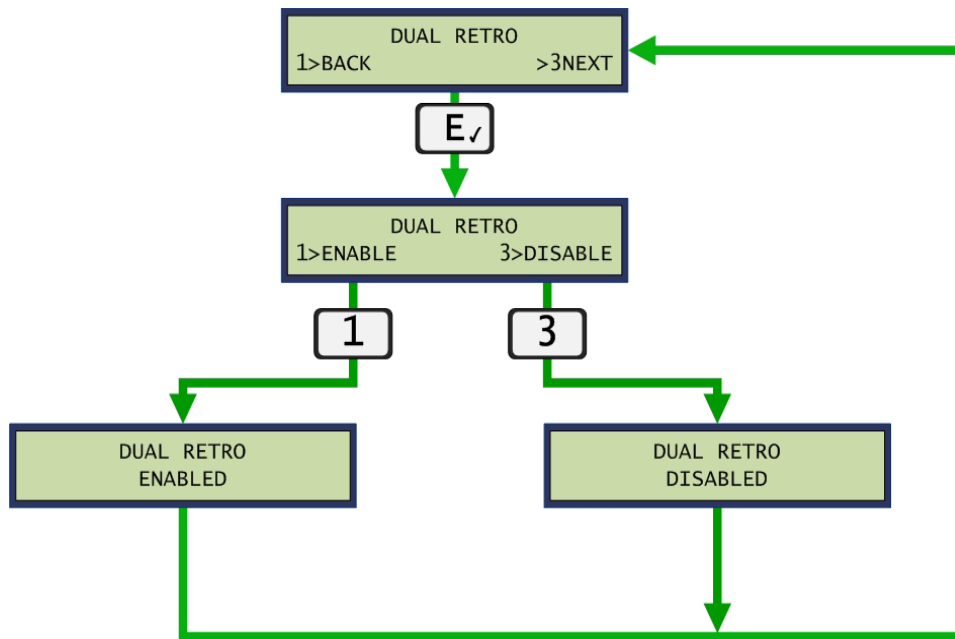

CODAX ACCESS TERMINAL OWNERS MANUAL

3.2.11 WASH QUEUING

The *Wash Queuing* option is only available for the Brush Wash service when Smartcard is in use. The *Wash Queuing* function is enabled or disabled here.

See section 5.5.2 - BRUSH WASH UK MODE WASH QUEUING, for details on using this facility.

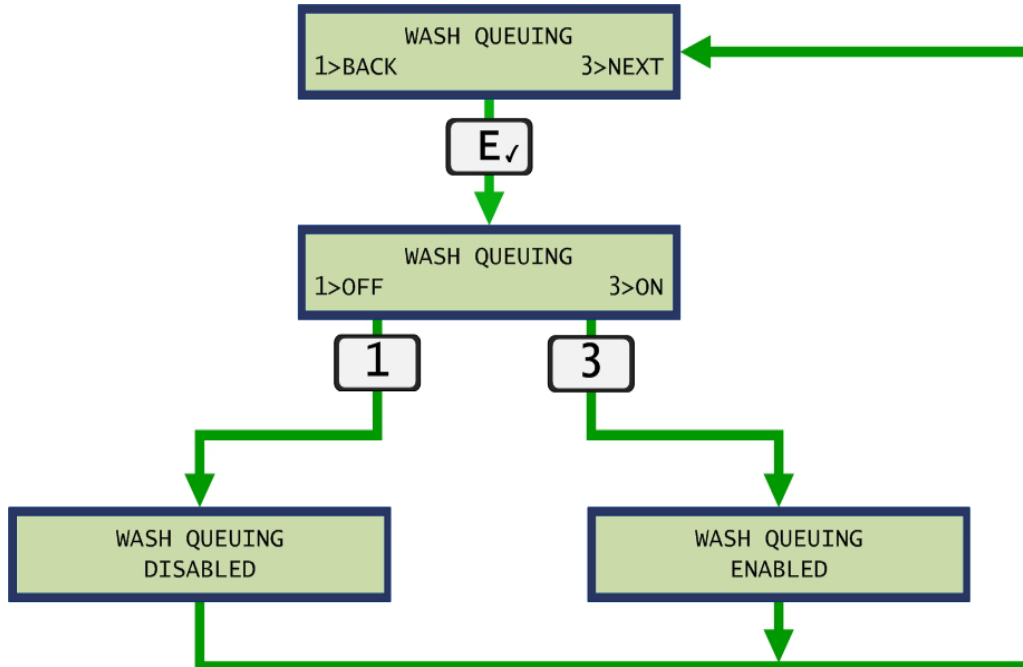

CODAX ACCESS TERMINAL OWNERS MANUAL

3.2.12 PROGRAM BLOCKING

The *Program Blocking* option allows specific programs to be excluded from the machine's program range. This facility is primarily used for multiple Brush Wash machine installations. If some programs are not available for one or more of the machines, they can be excluded at the CAT using this setup function.

The *CLEAR* option enables all programs and clears the blocking facility. The *EDIT* option allows each program available to be turned *ON* or *OFF*. Programs set *OFF* are blocked.

Note: This facility is primarily intended for Brush Wash use, but is not restricted to this machine type.

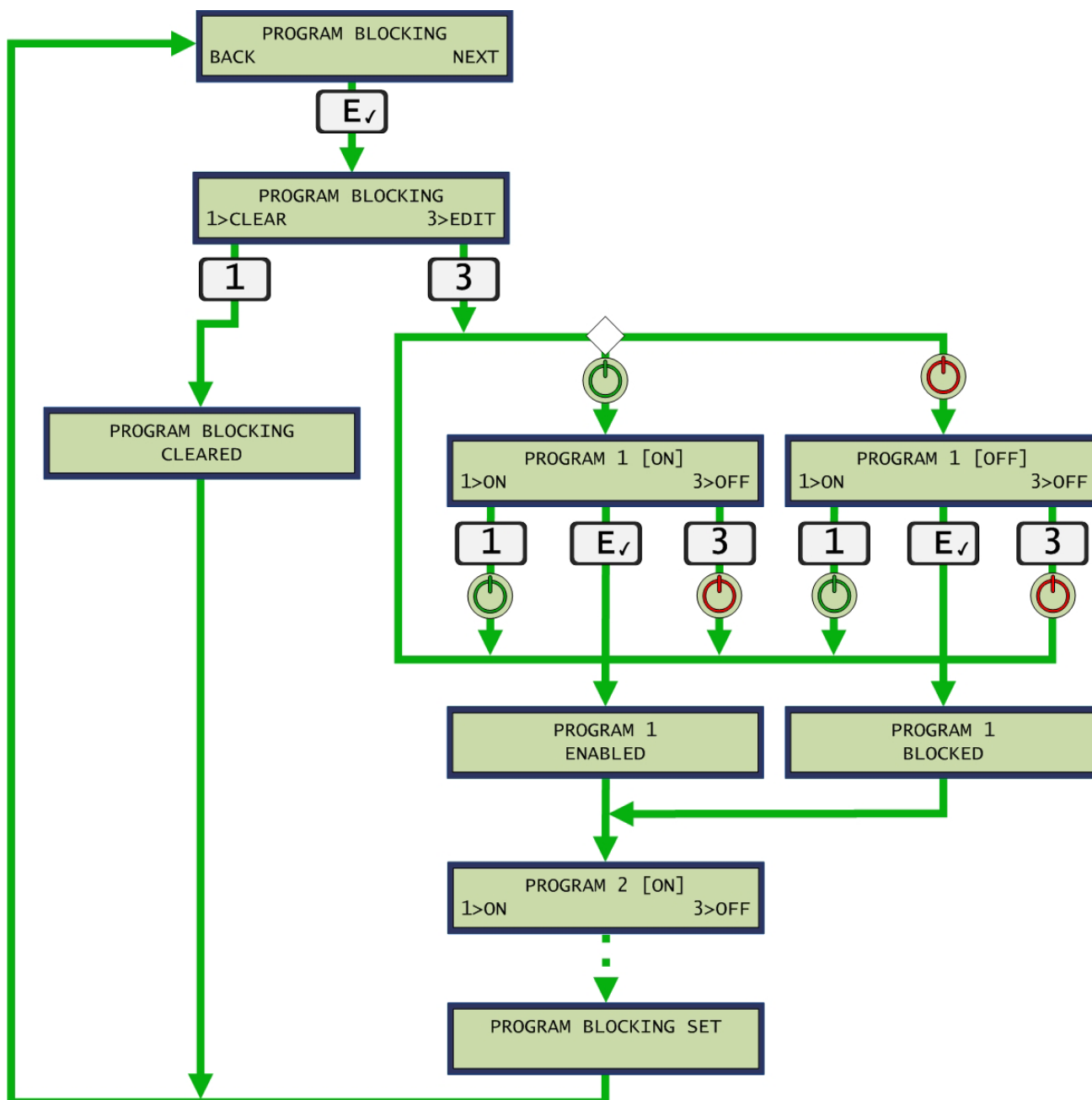

CODAX ACCESS TERMINAL OWNERS MANUAL

3.2.13 SITE CLOSURE

The *Site Closure* function allows machine operation to be suspended out of hours. Here the site opening and closing times are entered. Times are entered as hours and minutes in ten minute intervals. When the site is closed the following message (example) scrolls across the screen. See section 5.3 - *SITE OPERATING TIMES*.

“SITE OPENING TIMES: 8:30 to 22:00”

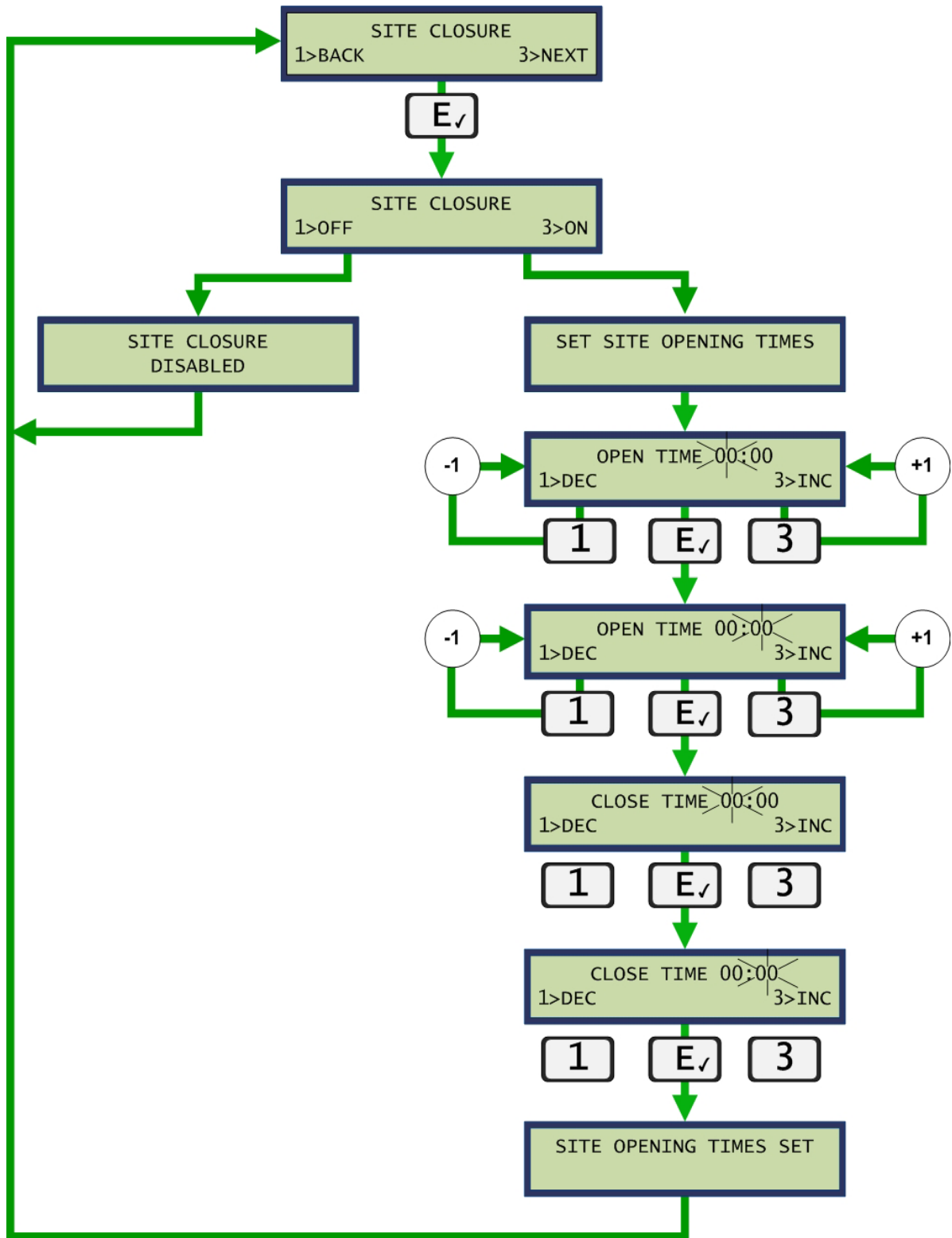

CODAX ACCESS TERMINAL OWNERS MANUAL

3.2.14 SOFTWARE VERSION

The *Software* option displays the software version of the Codax Access Terminal firmware and the E2PROM memory module.

Language Module

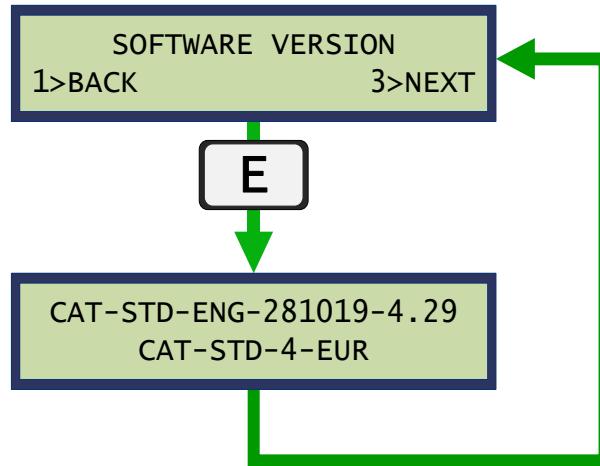

Language Options

Regional language options are included in the E2Prom memory module. The region identifier is embedded in the module version code. The following languages are available.

Code	Region	Language
EUR	European	German French Dutch Italian Spanish Portuguese
EEU	Eastern European	Bosnian Croatian Czech Hungarian Slovakian Slovenian
BAL	Baltic	Estonian Latvian Lithuanian Polish
SCN	Scandinavian	Danish Finish Norwegian Swedish

3.3 ACCESS CODES

Access codes allow individual service and setup functions to be accessed by entering a unique code.

Access codes are entered after pressing and holding the  key for a few seconds.

2222 Set Time and Date

Set internal time and date setting – See Section 3.2.2 - SET TIME AND DATE.

2223 Monitor Clock

Show current time and date setting until any key is pressed.

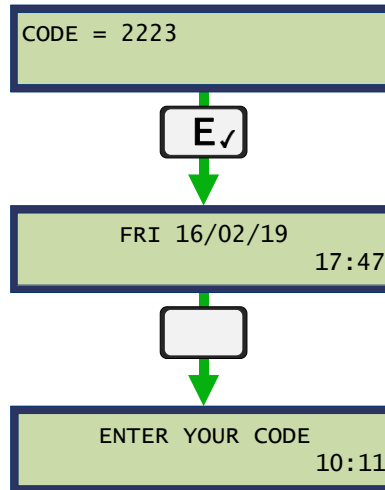

2360 Program Base

Set program base setting for Retro mode only – See section 3.2.6 - SET PROGRAM BASE.

2361 Enable Machine Link

The machine link refers to the electrical connection between the Codax Access Terminal and the automatic car wash machine. This access code enables that connection.

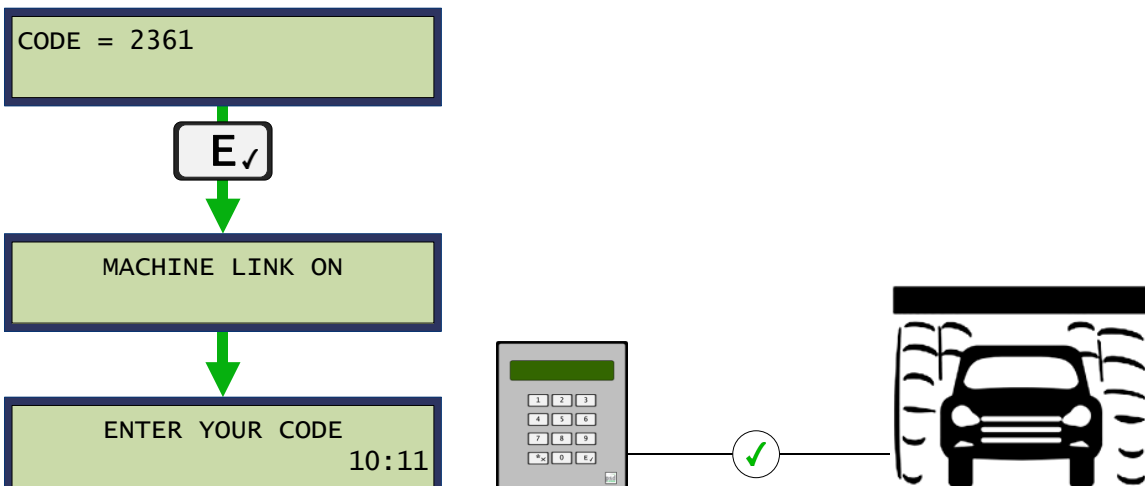

CODAX ACCESS TERMINAL OWNERS MANUAL

2362 Disable Machine Link

The machine link refers to the electrical connection between the Codax Access Terminal and the automatic car wash machine. This access code disables that connection for testing purposes.

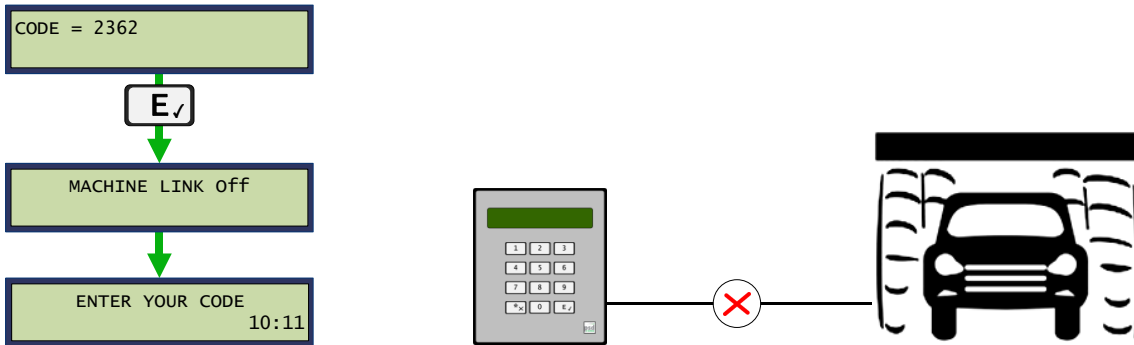

2363 Test Kiosk Link (ULTRA ONLY)

The kiosk link refers to the connection between the Codax Ticket Terminal and the Codax Access Terminal via the Codax Distribution Unit. This Access code is used to test communication via that link.

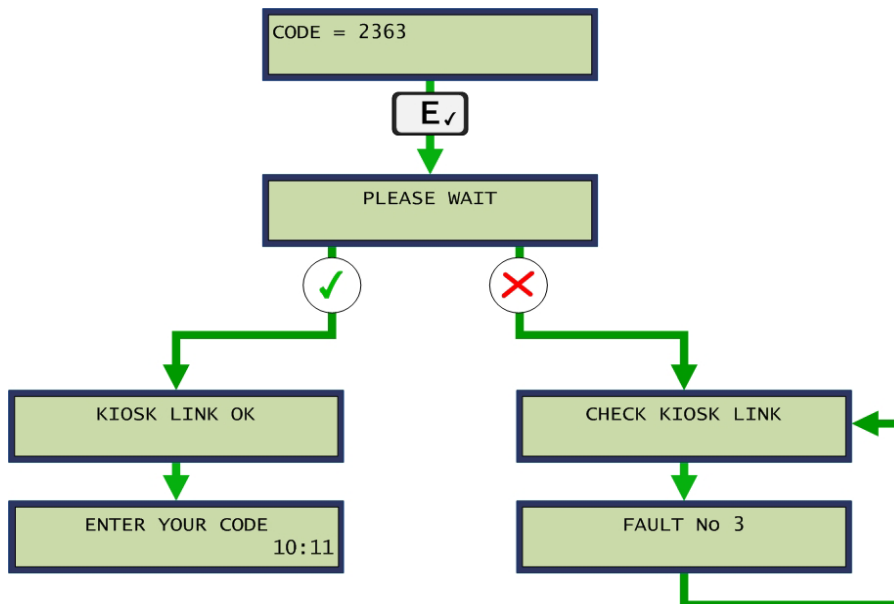
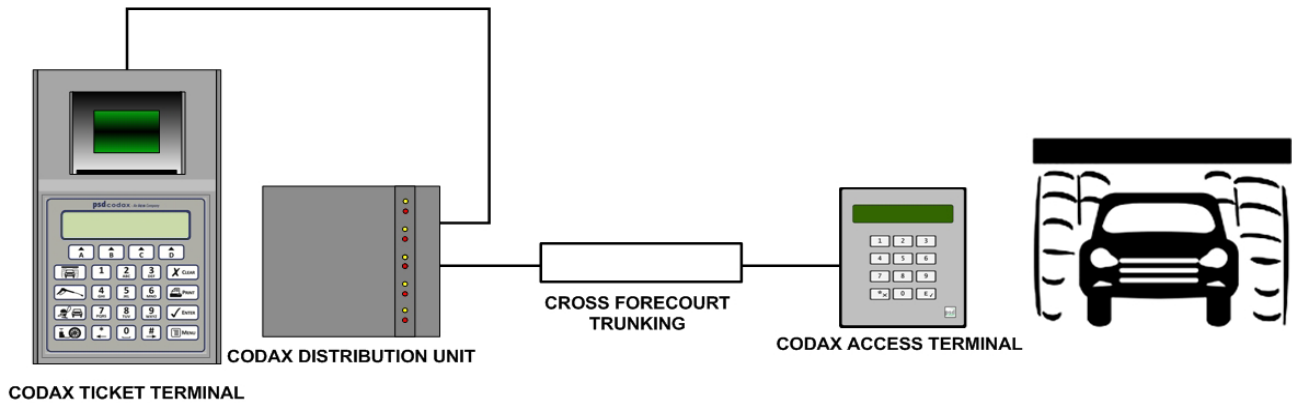

CODAX ACCESS TERMINAL OWNERS MANUAL

2364 System Setup

Enter system setup code – See section 3.2.5 - SYSTEM SETUP.

2365 Start up Sequence

This function displays the start up screen sequence as in a power up. This sequence shows the terminal configuration. See section 2.6.1 - POWERING UP THE ACCESS TERMINAL.

2369 Exit Test Mode

Test mode is enabled for new systems. On completing the installation the test mode is ended using this code.

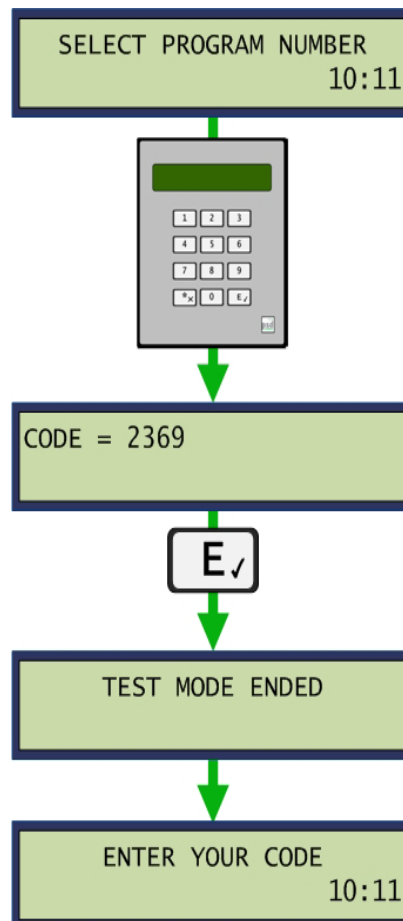

6723 Software Version

Show software and module version – See section 3.2.14 - SOFTWARE VERSION.

6728 Language Selection

The Access Terminal contains a base language with optional additional languages contained on the removable E2PROM memory module. This Access code allows those languages to be loaded. See section 3.2.3 - SELECT LANGUAGE.

CODAX ACCESS TERMINAL OWNERS MANUAL

1379 Ticket Check (RETRO ONLY)

The ticket check facility is available for Retro mode only. Ticket checking for Ultra mode is available at the Codax Ticket Terminal. On entering the Access code the six-digit ticket code is entered and one of the results shown in the following illustration is given according to ticket status.

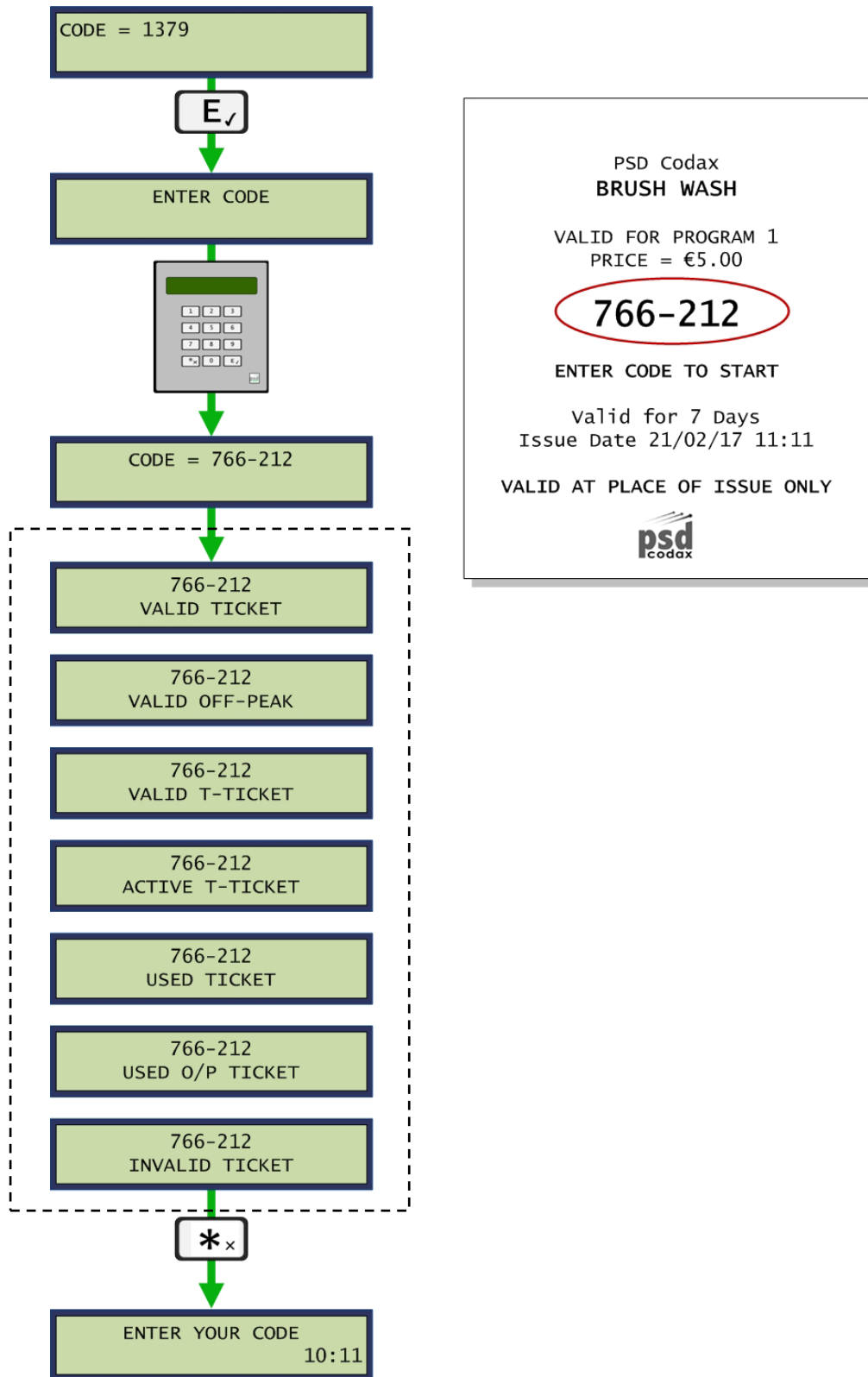

CODAX ACCESS TERMINAL OWNERS MANUAL

9999 Test Dual Retro Link (UPGRADE OPTION)

This function is available when operating in Dual Retro mode and is used to test the communications link between the two Access Terminals.

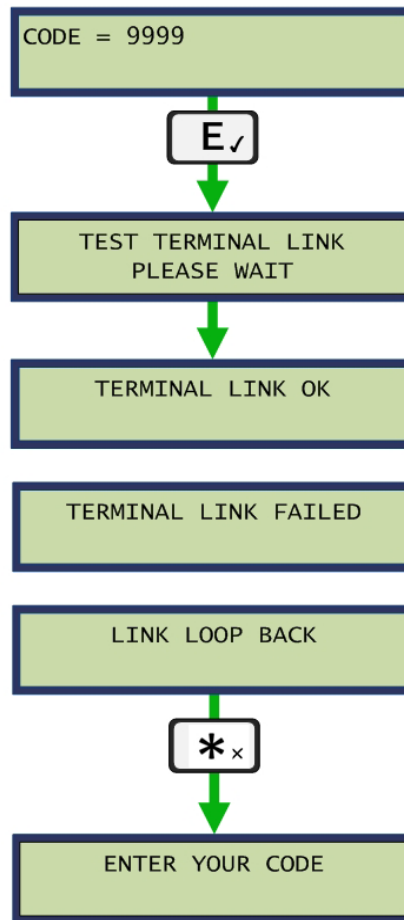
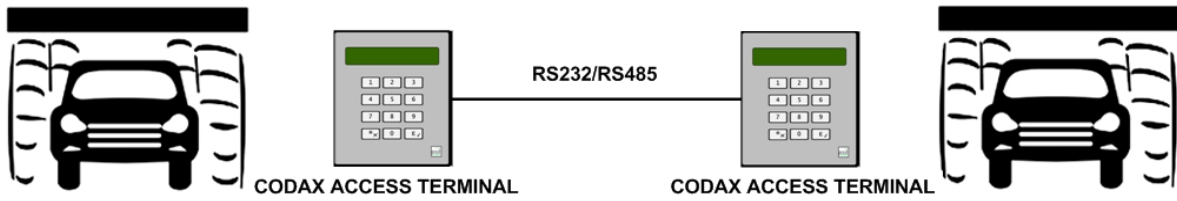

4 MACHINE SETUP

The CAT is factory set to operate for a single specific machine type only. Machine types include Auxiliary for non-automated systems and a number of manufacturer specific automated Brush Wash systems. See section 2.7 MACHINE LINK CONTROL for a full list of all machine types supported.

This section defines the options available to setup Auxiliary and Brush Wash machines.

4.1 AUXILIARY MACHINE SETUP

Auxiliary machine type is used to control non-automated equipment such as Jet Wash, Vacuum and Tyre Inflation bays.

Timed and Pulsed control modes are available from the Machine Setup function.

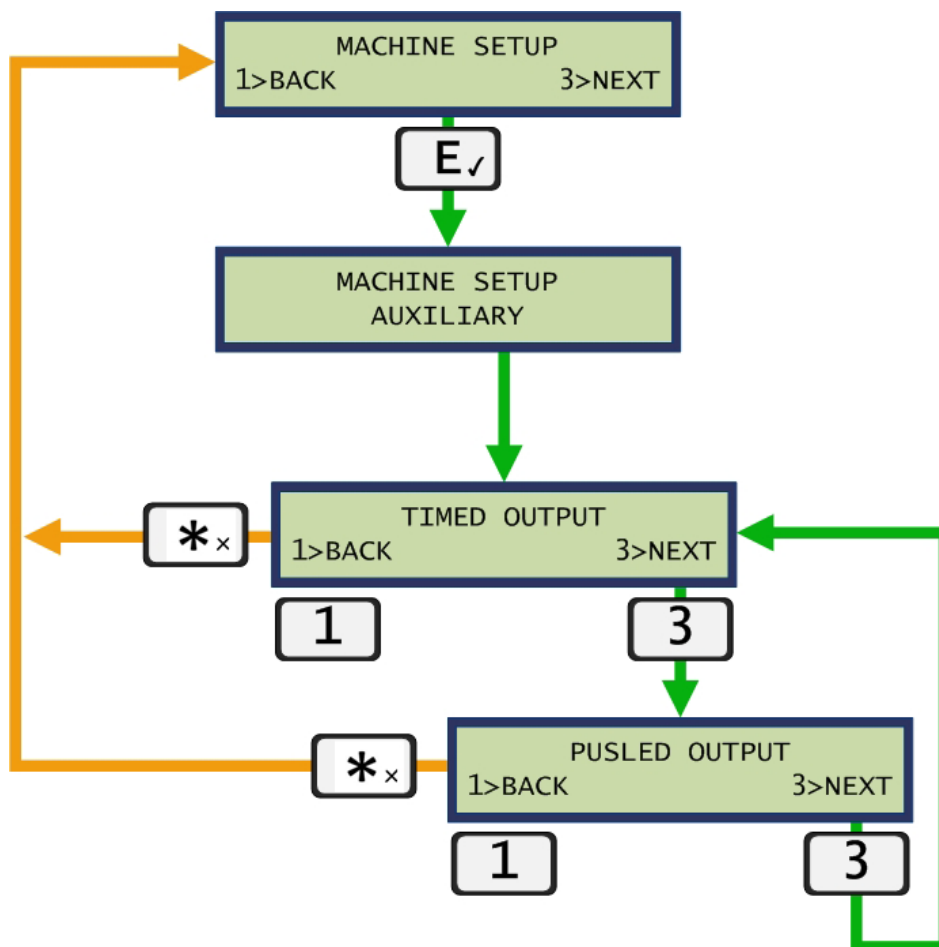

CODAX ACCESS TERMINAL OWNERS MANUAL

4.1.1 TIMED OUTPUT MODE

For *Timed Output* mode the machine outputs remain high for a period of time. The amount of time allocated for each program is determined by the operator when *Timed Output* mode is selected. Machine outputs 1 and 2 activate for the duration of the program.

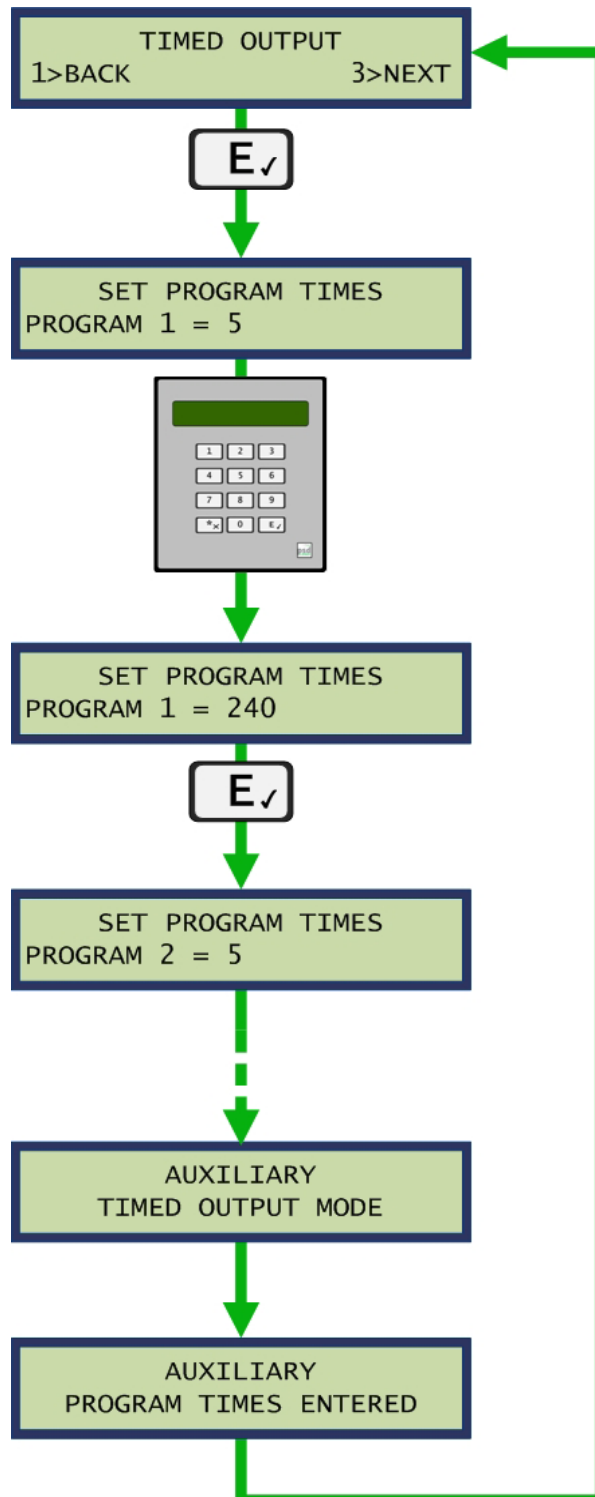

4.1.2 PULSED OUTPUT MODE

For Pulsed Output mode the machine outputs are pulsed to start the wash. Two pulsed modes are available.

Pulsed Mode 1

This mode simply outputs the pulsed control sequence to the machine.

Pulsed Mode 2

This mode outputs the control signal to the machine and includes a Machine Busy signal back from the machine. The Machine Busy signal is connected to machine input 2 with a low level indicating the machine is busy.

Pulsed mode program selection uses machine outputs 1 and 2 simultaneously to provide the pulsed control signal. The following signal variations are available in this mode. *See Section – 4.3 - MACHINE OUTPUT CONTROL SIGNAL VARIATIONS.*

Binary Program Selection

For Binary program selection, the machine outputs a binary coded representation of the program number.

Pulses per Program

For Pulses per Program the machine outputs pulse a number of times to select a program number. The number of pulses used to select a particular program is specified by the user.

CODAX ACCESS TERMINAL OWNERS MANUAL

Custom Program Selection

The Custom output option allows the operator to define how the machine outputs operate to select each program. See section 4.1.3 Pulsed Output Program Selection.

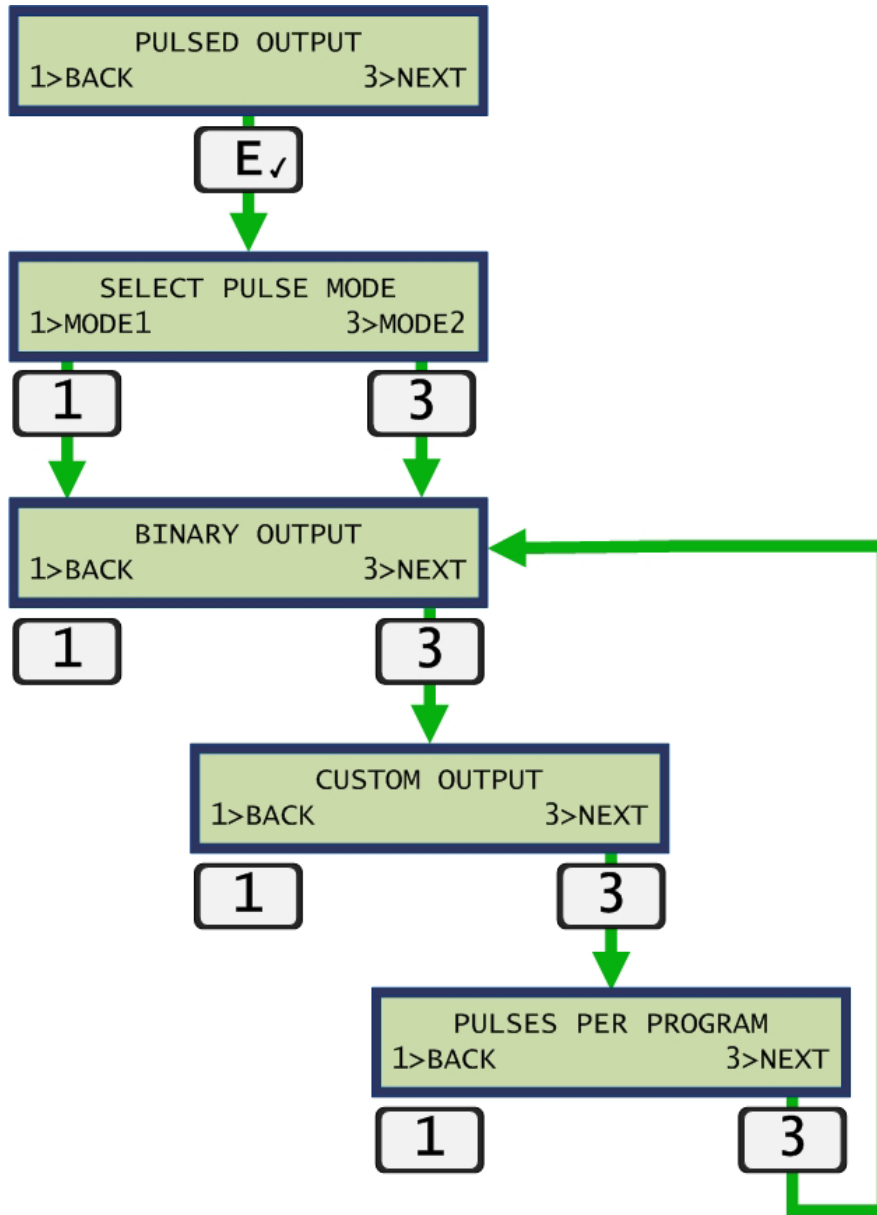

4.2 BRUSH WASH MACHINE SETUP

For a Brush Wash machine setup the operation and control options available for that machine type are presented to the operator. The following sub-sections outline all operation and control options available, some of which will not be relevant to all machine types.

4.2.1 OPERATING MODES

UK Mode

For UK mode the user enters the six-digit Codax code, drives into the car wash and remains in the vehicle during the wash.

Euro Mode

For Euro mode the user drives into the car wash and exits the vehicle. The six-digit Codax code is entered and the user remains out of the vehicle during the wash. On completion the user re-enters the vehicle and exits the car wash.

4.2.2 MACHINE INPUTS

The availability and state of the following machine input signals will vary according to the Machine type.

The active states of the machine inputs will also vary with machine type and may be Active High or Active Low, where:

Active Low Signal is active when input is at 0v or Off
Active High Signal is active when input is at +24V or On

Machine Present

The Machine Present signal is used as an indication that the machine has power. This signal remains active at times and will result in fault code 2 if the signal is lost.

Machine Busy

The Machine Busy signal goes active (high or low) when a vehicle enters the machine. The signal remains active throughout the wash and goes inactive when the vehicle exits the machine.

Code Acknowledge

The Code Acknowledge signal goes active (high or low) in response to receiving a program start signal from the CAT. Code Acknowledge remains active throughout the wash and goes inactive when the vehicle exits the machine. If the Code Acknowledge signal does not respond to a program start signal within five seconds, this will result in fault code 1 being reported.

Machine Reset

The Machine Reset signal indicates the end of the wash. This signal goes active (high or low) to indicate the end of the wash sequence and returns inactive to indicate the machine is ready to accept the next code.

Vehicle in Machine

The Vehicle in Machine signal is normally used in Euro mode to indicate when a vehicle is present. This signal goes active (high or low) to indicate a vehicle has entered the car wash and returns inactive when the vehicle exits. This signal is normally using in conjunction with a Machine Busy, Code Acknowledge or Machine Reset input signal to operate the machine.

Frost Shutdown

The Frost Shutdown signal is available for certain machine types for protection in low temperature situations. If this signal goes active (high or low) the CAT goes offline until the signal returns to inactive.
Note: The active state of the above signals varies with machine type.

4.2.3 PROGRAM SELECTION/START OUTPUTS

The CAT has a series of six machine outputs to provide program selection/start control signals. The following signal variations are available according to machine type. See Section 4.3 MACHINE OUTPUT CONTROL SIGNAL VARIATIONS.

Binary Program Selection

For Binary program selection, the machine outputs a binary coded representation of the program number.

Binary Plus Program Selection

Binary Plus output is a special program mode used by the Tammermatic machine type.

1 of 6 Program Selection

This control method is available for up to six programs. Output 1 selects program 1, output 2 selects program 2, and so on up to program 6.

Pulses per Program

For Pulses per Program the machine outputs pulse a number of times to select a program number. The number of pulses used to select a particular program is specified by the user.

Custom Program Selection

The Custom output option allows the operator to define how the machine outputs operate to select each program. See section 4.1.3 Pulsed Output Program Selection.

4.2.4 APPLICATION OF PROGRAM CONTROL SIGNALS

The following options define how the program selection/start signal is applied.

Hold

For Hold control the signal is applied and held until the machine responds. This may be via a Machine Busy, Code Acknowledge or Machine Reset signal, according to machine type.

Pulse

For Pulse control the signal is pulsed for one or two seconds according to machine type and is independent of the signal inputs.

Note: The operation of certain machine types is fixed and no Hold/Pulse option is given during setup.

CODAX ACCESS TERMINAL OWNERS MANUAL

4.2.5 MACHINE SETUP SEQUENCE

The following illustration shows a typical machine setup sequence. The example shown is for machine type Ryko Italian. The sequence will vary for other machine types.

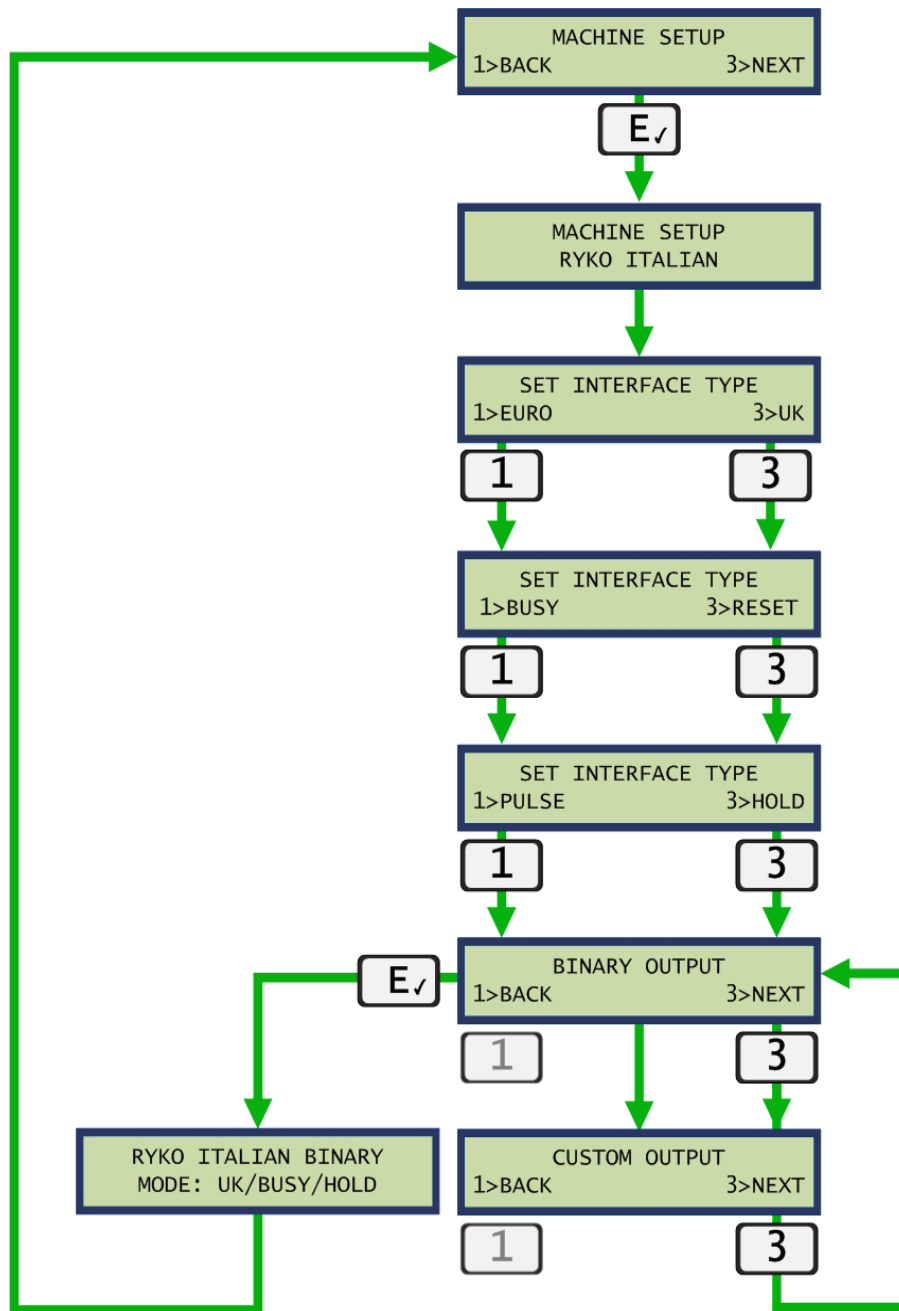

4.3 MACHINE OUTPUT CONTROL SIGNAL VARIATIONS

Binary Output

The Binary Output option uses a fixed binary pattern to select a program number.

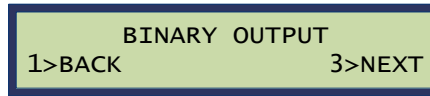

The following table illustrates the binary output pattern over the first eight program selections.

Program	Output Pattern
1	① ② ③ ④ ⑤ ⑥
2	① ② ③ ④ ⑤ ⑥
3	① ② ③ ④ ⑤ ⑥
4	① ② ③ ④ ⑤ ⑥
5	① ② ③ ④ ⑤ ⑥
6	① ② ③ ④ ⑤ ⑥
7	① ② ③ ④ ⑤ ⑥
8	① ② ③ ④ ⑤ ⑥

1 of 6 Output

The 1 of 6 option simply activates relay 1 for program 1 and relay 2 for program 2 etc. This method is limited to a maximum of 6 programs.

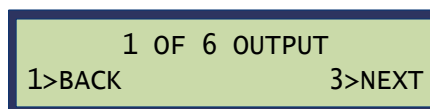

The following table illustrates the 1 of 6 output pattern over the entire range.

Program	Output Pattern
1	① ② ③ ④ ⑤ ⑥
2	① ② ③ ④ ⑤ ⑥
3	① ② ③ ④ ⑤ ⑥
4	① ② ③ ④ ⑤ ⑥
5	① ② ③ ④ ⑤ ⑥
6	① ② ③ ④ ⑤ ⑥

CODAX ACCESS TERMINAL OWNERS MANUAL

Pulses Per Program

In *Pulses Per Program* mode a program is selected by pulsing the machine outputs a predetermined number of times. On selecting the *Pulses Per Program* mode the operator enters number of times the machine outputs will pulse to select program 1. Similarly the pulses required to select all programs available are specified. During program selection, machine outputs 1 and 2 are pulsed on and off at one second intervals.

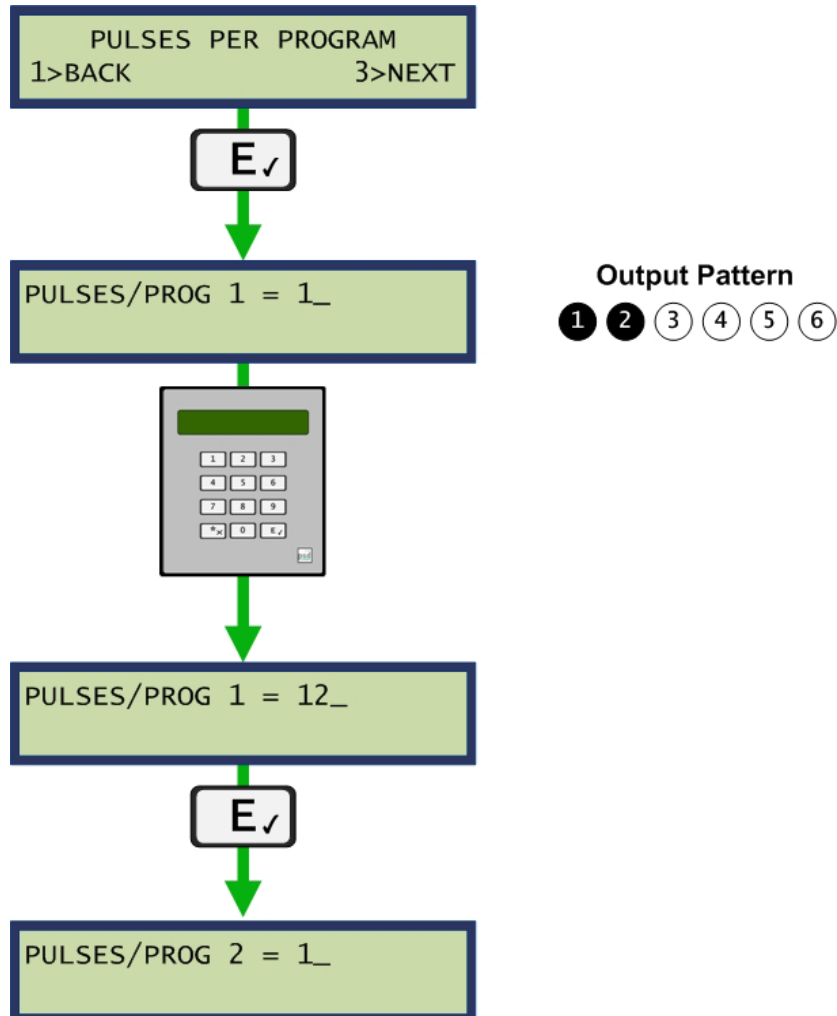

CODAX ACCESS TERMINAL OWNERS MANUAL

Custom Output

The *Custom Output* mode allows the user to define the relay output pattern used to select programs at the machine. This output pattern is represented by six-digits initially all zero. Digit 1 represents output relay 1 and 2 represents relay 2, up to relay 6. Press 1 on the keypad and digit 1 is shown on the display. This indicates that relay 1 will engage during the selection of program 1. Press 1 again and the digit 1 is replaced by 0 indicating relay 1 is not engaged in the selection of program 1. Using this method of pressing digit 1 to toggle relay 1 and digit 2 to toggle relay 2, etc, the operator may set a custom relay pattern to control each program as required. This sequence is illustrated below.

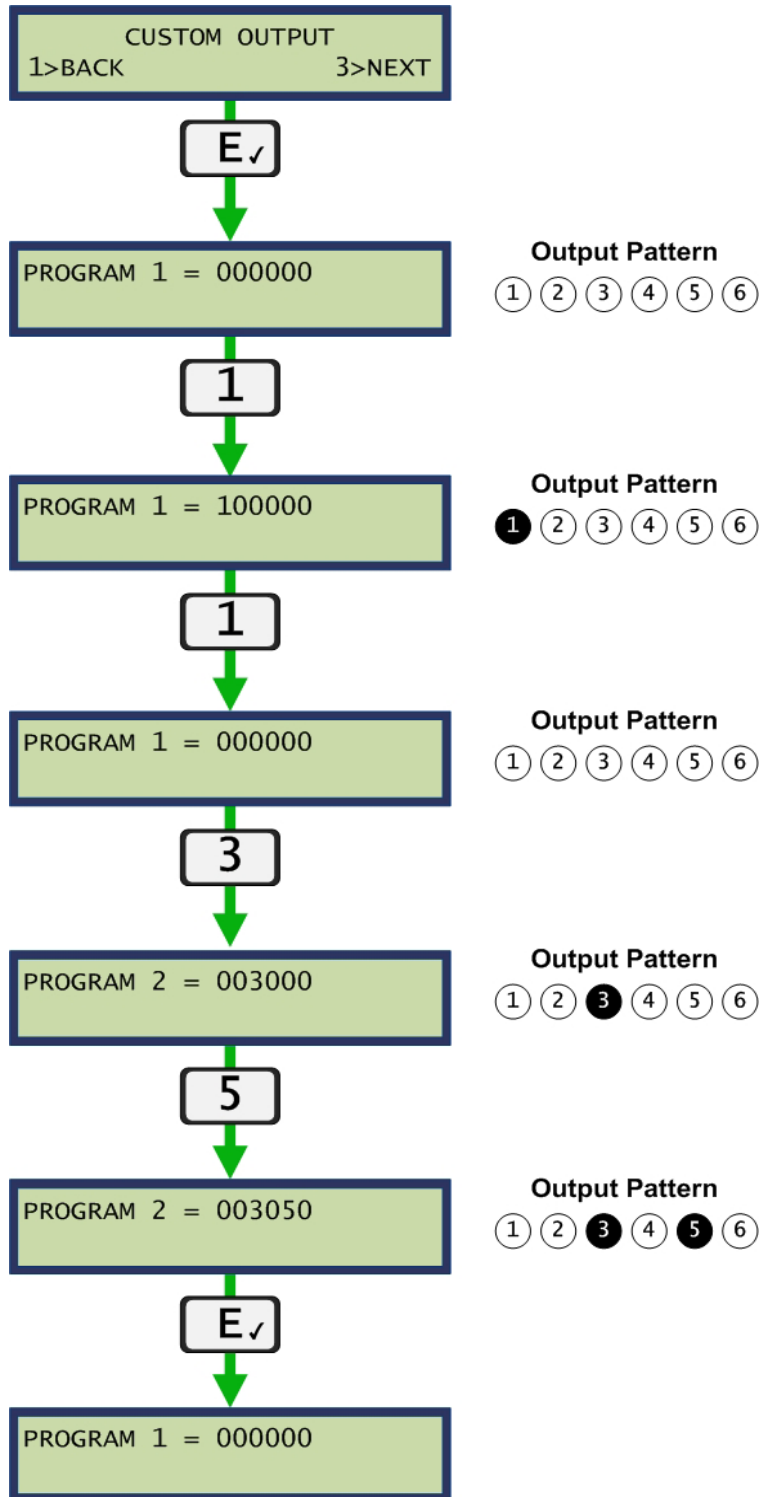

5 USER FUNCTIONALITY

5.1 CODAX CODE ENTRY

5.1.1 NUMERIC CODE ENTRY

Numeric code entry is done by simply keying in the code. On entering the sixth digit the number is automatically processed.

 The *Star Key* may be used to delete an entry.

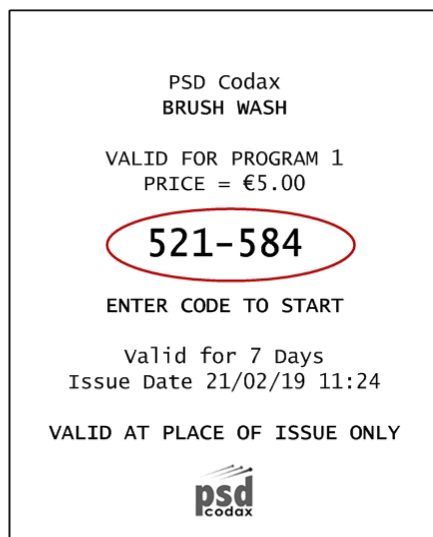
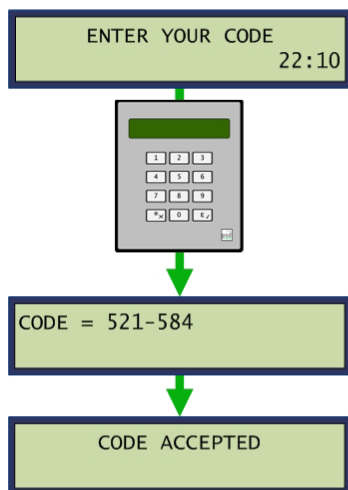

5.1.2 BARCODE ENTRY

Barcode entry is available if the Barcode reader option is included. Here the ticket is simply placed under the scanner.

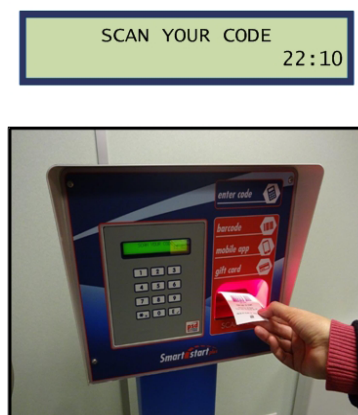

CODAX ACCESS TERMINAL OWNERS MANUAL

5.1.3 MULTI-USE TICKETS (ULTRA OPTION)

Multiple use tickets are available for use a number of times. Each time the ticket is used the number of washes left is shown. When all the washes have been used the ticket is no longer accepted.

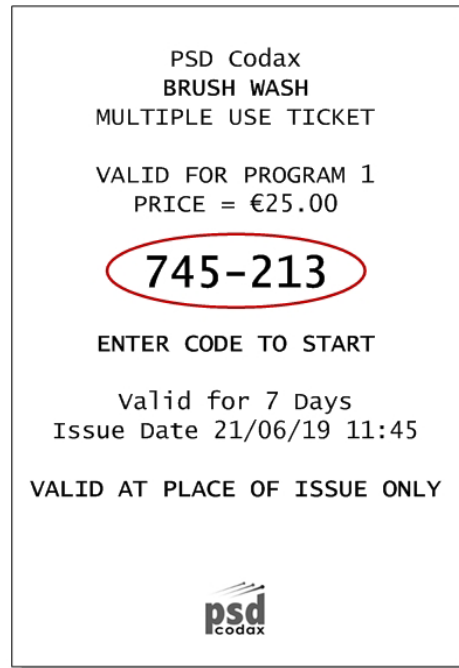
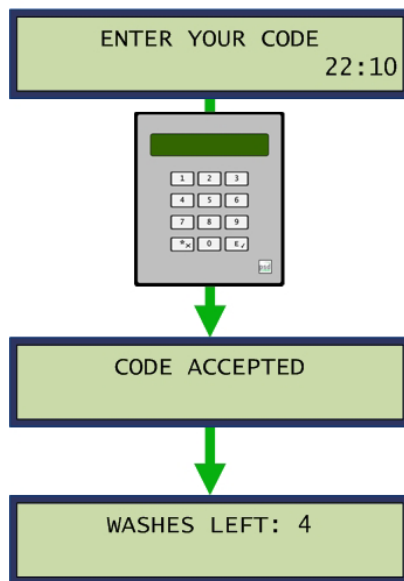

5.1.4 OFF-PEAK CODES

During the off-peak period, off-peak tickets are accepted as normal tickets. If an off-peak code is entered outside the off-peak time the code is not allowed.

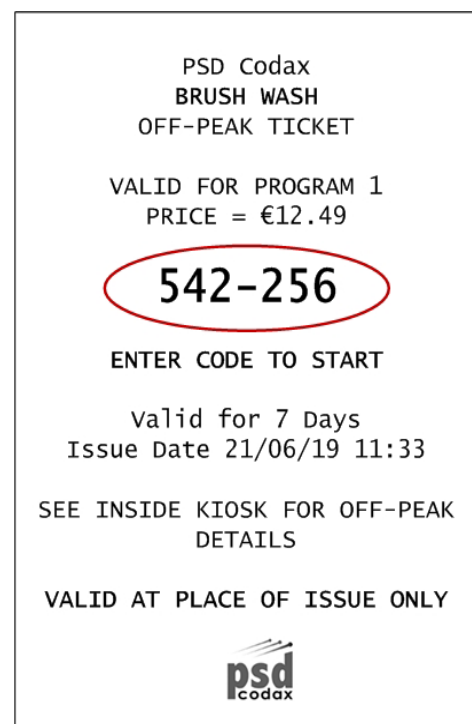
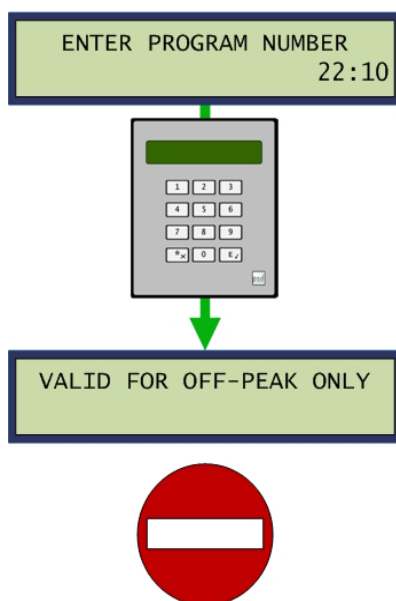

5.1.5 INVALID CODE ENTRY

If a code is entered that is not recognised by the system as a valid code, the invalid code message is shown.

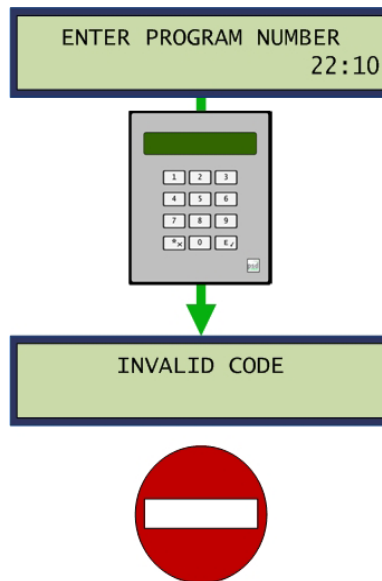

5.1.6 KEYING ERROR

The Keying Error occurs if an invalid code is entered four times in succession. This may indicate a faulty keypad but is also used to discourage random code entry at the Codax Access Terminal. The fault remains on the screen for 20 seconds before being automatically cleared.

In *Ultra Mode* the fault is reported back to the *Ticket Terminal*. See section 6 - *TROUBLE SHOOTING*.

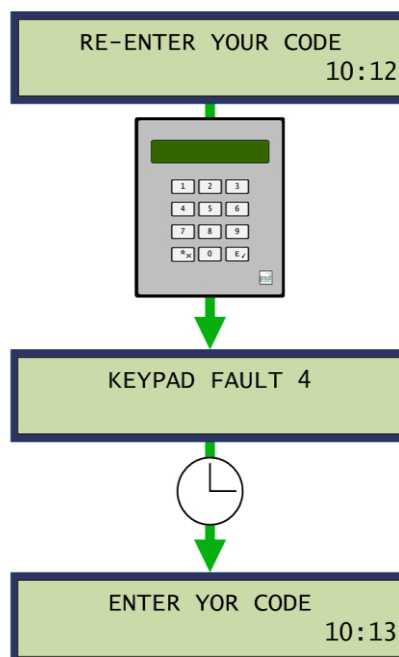

5.2 FROST SHUTDOWN

For machines using frost shutdown, the system becomes unavailable if the temperature falls below the operating limit. Codes and Smartcard transactions are not accepted whilst in this state.

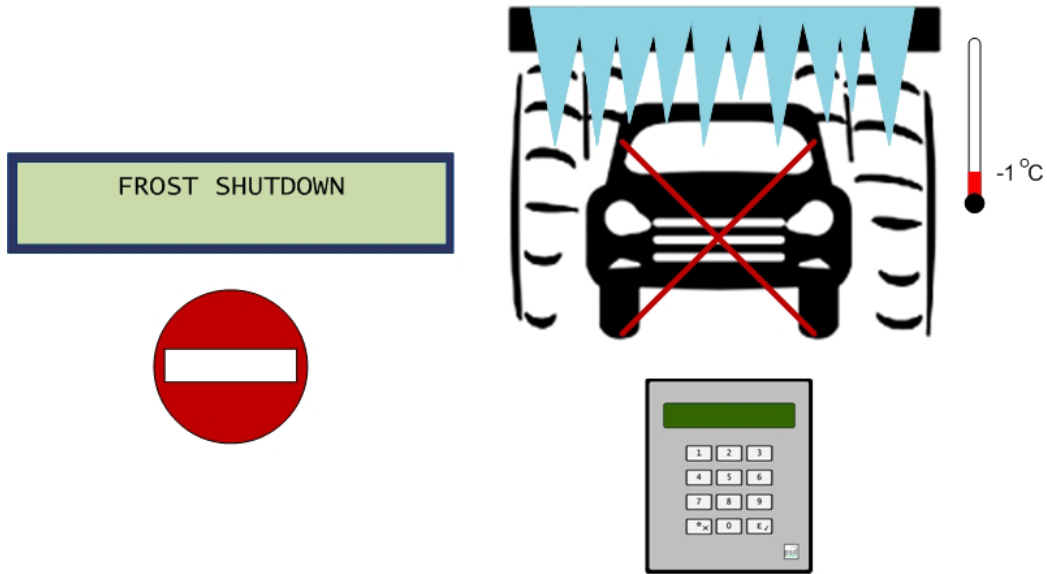

5.3 SITE OPERATING TIMES

If the site closure facility is used, the system becomes unavailable during the out-of-hours time as programmed by the operator. During the out-of-hours time, codes and Smartcard transactions are not accepted and the following message scrolls across the screen:

“SITE OPENING TIMES: 8:00 - 10:30”

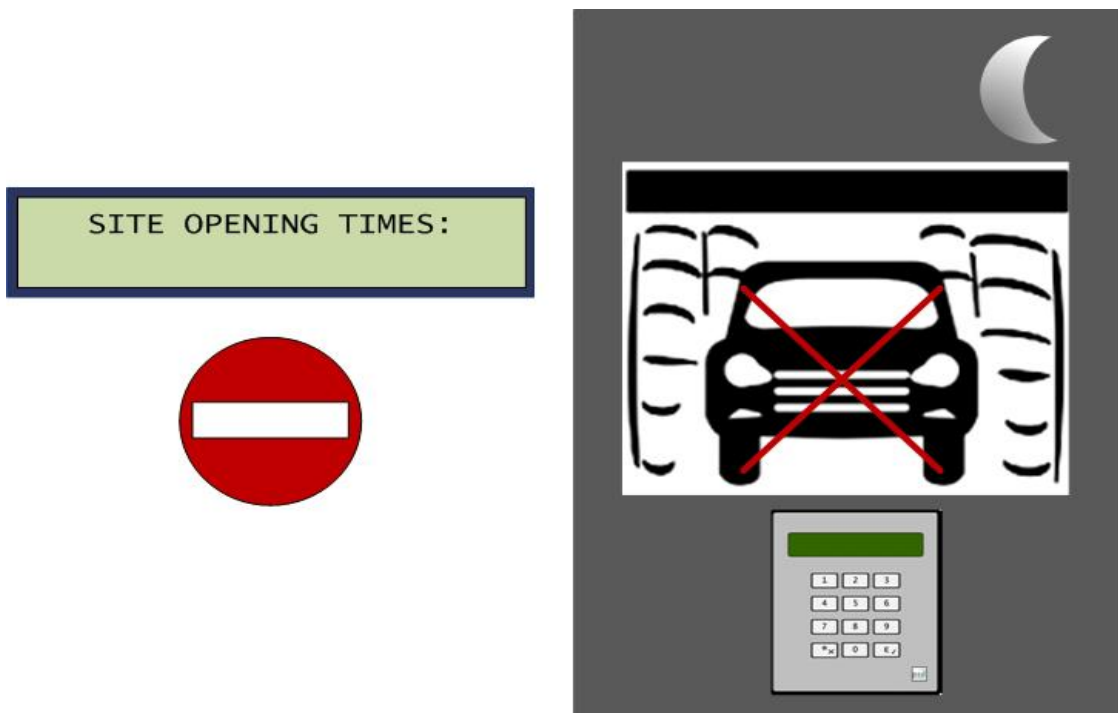

See section 3.2.13 - SITE CLOSURE, to set site operating times.

5.4 BLOCKED PROGRAM

If a code is entered for a program blocked by the *Access Terminal*, the *Program Blocked* message is shown. The user should retry the code at a different *Access Terminal*.

PROGRAM BLOCKED
USE OTHER MACHINE

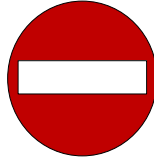

5.5 MACHINE RUNNING SEQUENCES

5.5.1 BRUSH WASH UK MODE

For UK mode the customer enters the six-digit Codax code, drives into the car wash and remains in the vehicle during the wash. Customer exits when wash is complete.

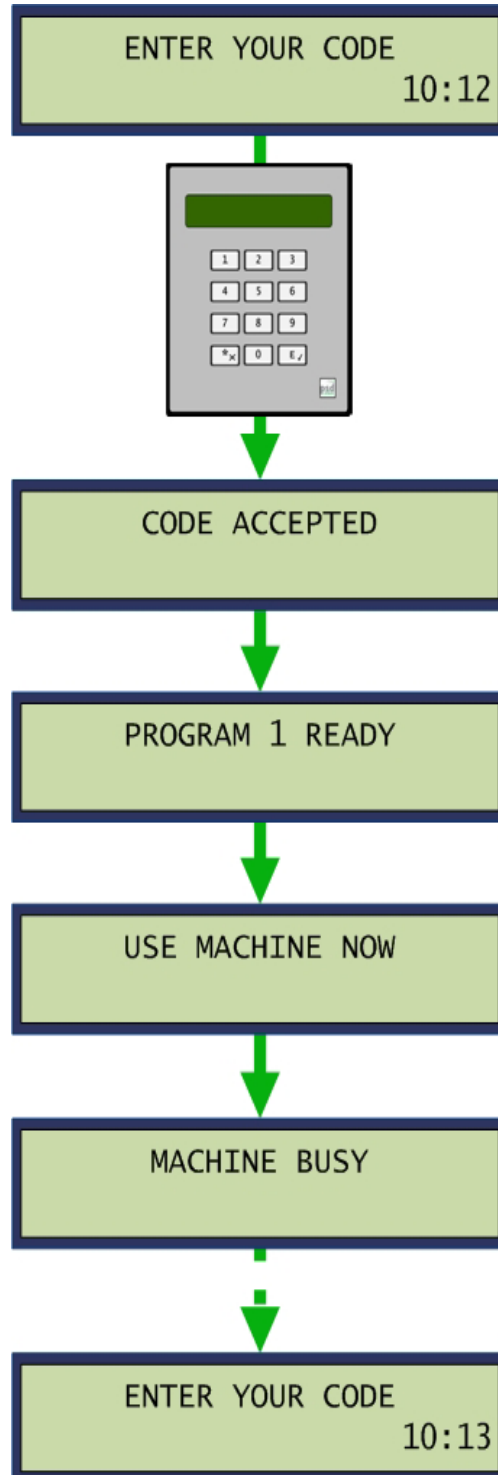

CODAX ACCESS TERMINAL OWNERS MANUAL

5.5.2 BRUSH WASH UK MODE WASH QUEUING

The Wash Queuing facility allows a new wash transaction to be completed while the machine is busy. This facility increases throughput when the Smartcard option is fitted and applies to Code redemption as well as Smartcard transactions. On completing the transaction the 'Wash Queued' message is displayed until the current wash is complete. The new wash is then started.

Wash Queuing availability is limited to the following conditions.

- The Machine is operating in UK mode
- The Smartcard option is included
- Wash queuing is not available for Washtec Softcare machine type

See section 3.2.11 - WASH QUEUING, for details on enabling this facility.

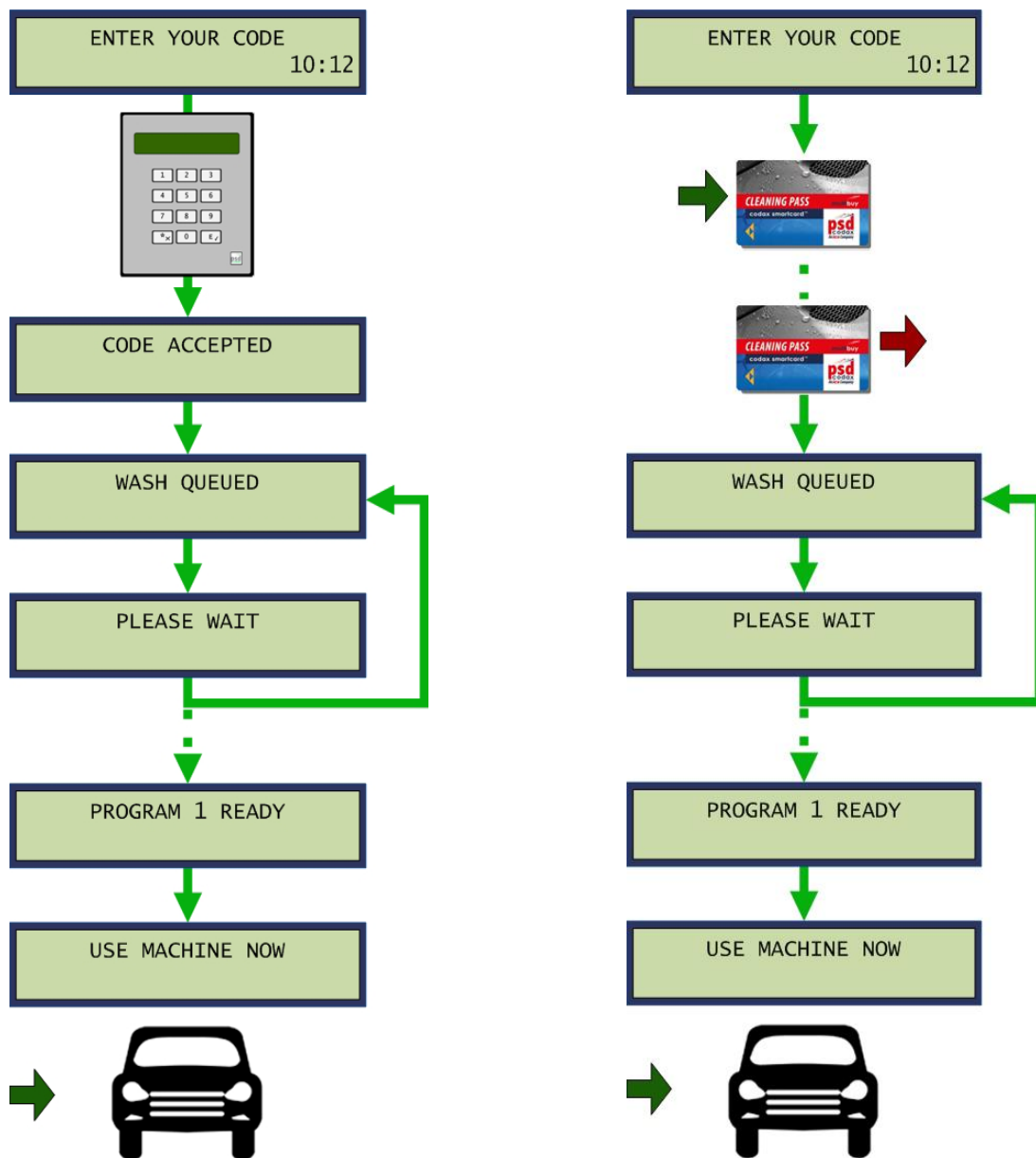

CODAX ACCESS TERMINAL OWNERS MANUAL

5.5.3 BRUSH WASH EURO MODE

For Euro mode the customer drives into the car wash and exits the vehicle. The customer then enters the six-digit Codax code and remains outside the vehicle while the wash completes. On completion the customer re-enters the vehicle and exits the wash.

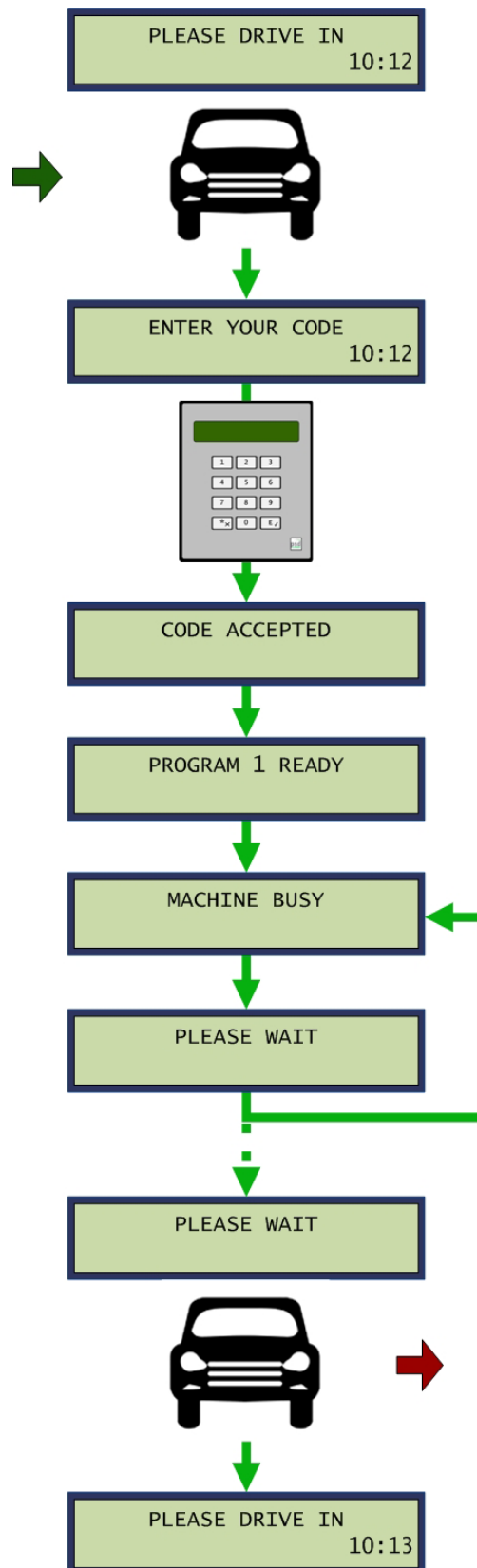

CODAX ACCESS TERMINAL OWNERS MANUAL

5.5.4 AUXILIARY

Timed mode

For timed mode each program is allocated a time value. When a code is accepted the allocated time for the respective program is elapsed. The time remaining is displayed as it counts down and a bar-graph decrements in length.

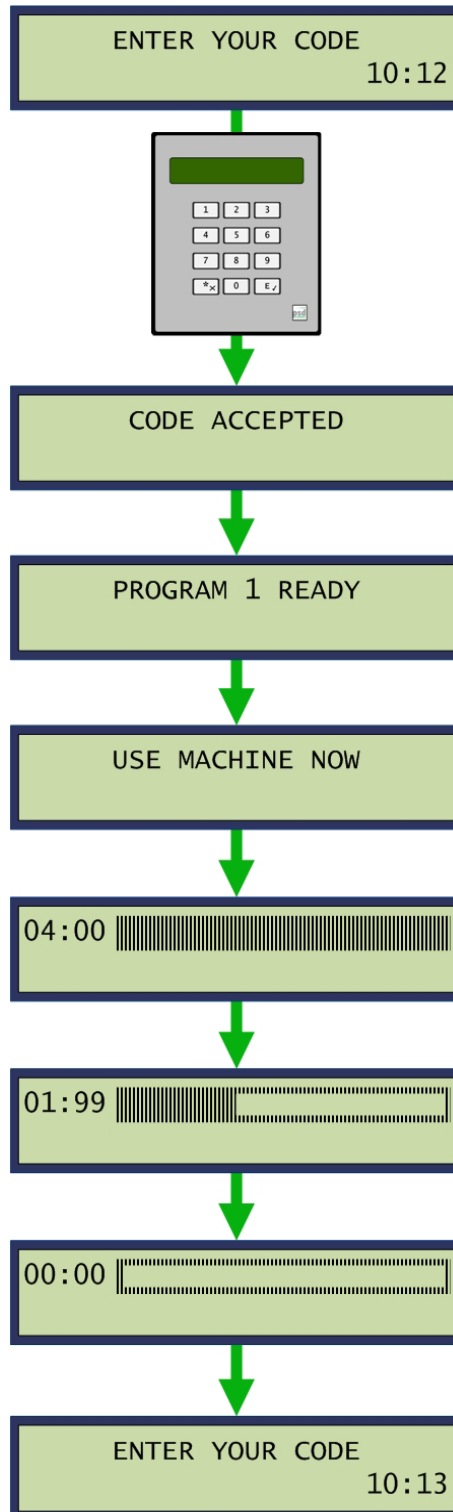

CODAX ACCESS TERMINAL OWNERS MANUAL

Pulsed mode

For pulsed mode each program is allocated a start code which is applied as a pulse to start the program. Two pulse modes are available. For Pulsed Mode 1 the code is applied and the 'Use Machine Now' message is displayed for 30 seconds before returning to the start screen. For Pulse Mode 2 the code is started by applying the code and a signal back from the machine indicates when the program is finished. During this time the 'Machine Busy' message is shown. Both machine sequences are illustrated below.

Pulsed Mode 1

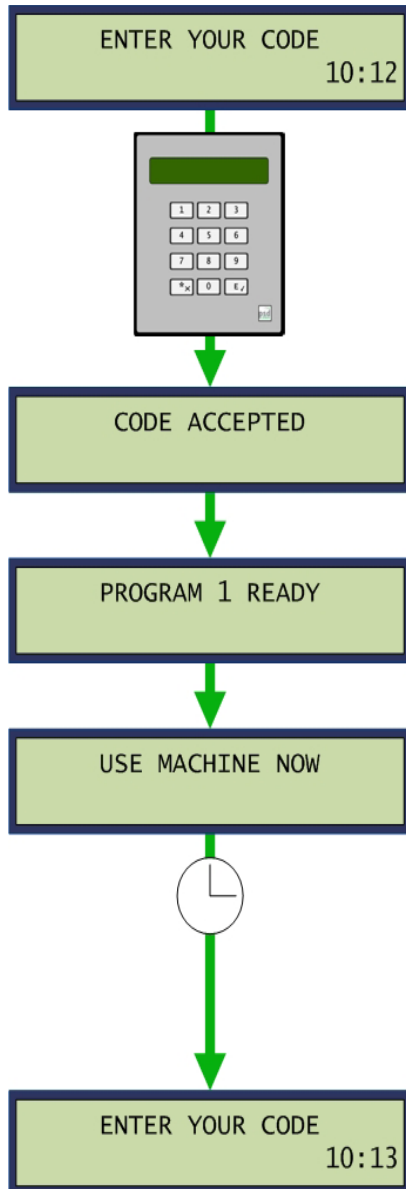

Pulsed Mode 2

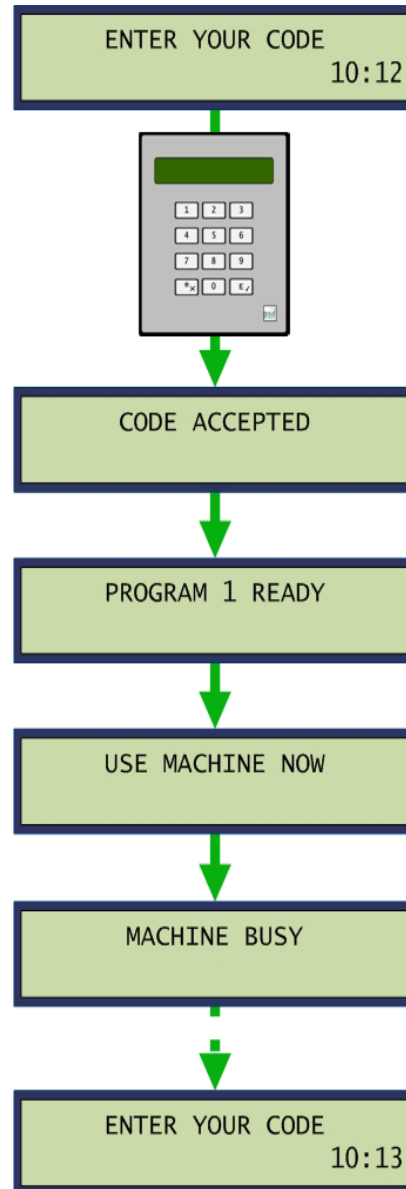

5.6 SMARTCARD

5.6.1 CARD PLACEMENT

To start a Smartcard transaction the card is simply placed into the Smartcard reader when the default welcome screen is shown.

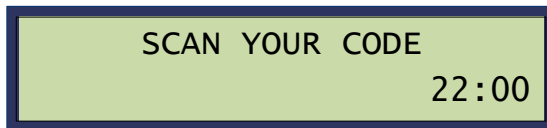
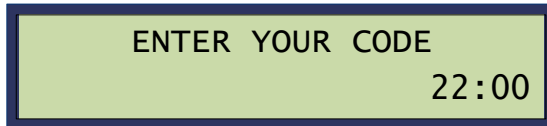

5.6.2 USER CARD TYPES

The Codax Access Terminal supports three Smartcard types:

Value Card

Credit is added to the card at the Codax Ticket Terminal. This is in the form of a promotional multi-buy package or a credit top-up. Each wash program is assigned a credit value as part of the terminal setup functions. The customer may redeem credit for wash programs when the card is placed in the Smartcard Reader. This card type may be used for any available program for which there is sufficient credit on the card.

Program Card

Programs are added to the card at the Codax Ticket Terminal. The customer will decide the wash program required as well as the number of washes. Discounts may be added to the cost of multiple programs. The customer may redeem a wash when the card is placed in the Smartcard Reader. This card type can only be used for the wash program specified when the card is purchased.

5.6.3 SMARTCARD SYSTEM MAINTENANCE

Admin Card



The Admin Card is included with all Codax systems using Codax Smartcard and is used to set the site identification number. This number is a four digit number unique to the site and prevents cards not issued to that site from being used. If the site Id has not been set the following screen is shown during the *Start Up* sequence. Smartcard transactions are not available until the site ID is set.

INSERT ADMIN CARD

The site identification number is set by placing the Admin card in each CAT with a Smartcard reader.

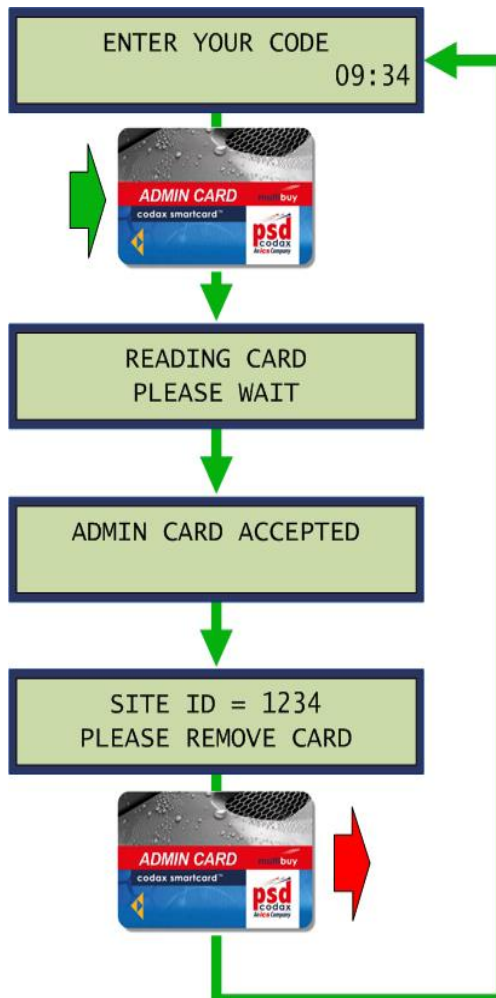

5.6.4 SMARTCARD TRANSACTIONS

Value Card Transaction

For Value Card transactions a program number is specified, the value of the transaction is shown and confirmed by pressing the 'E' key. On completing the debit the new balance and expiry date are shown and on removing the card the wash is started.

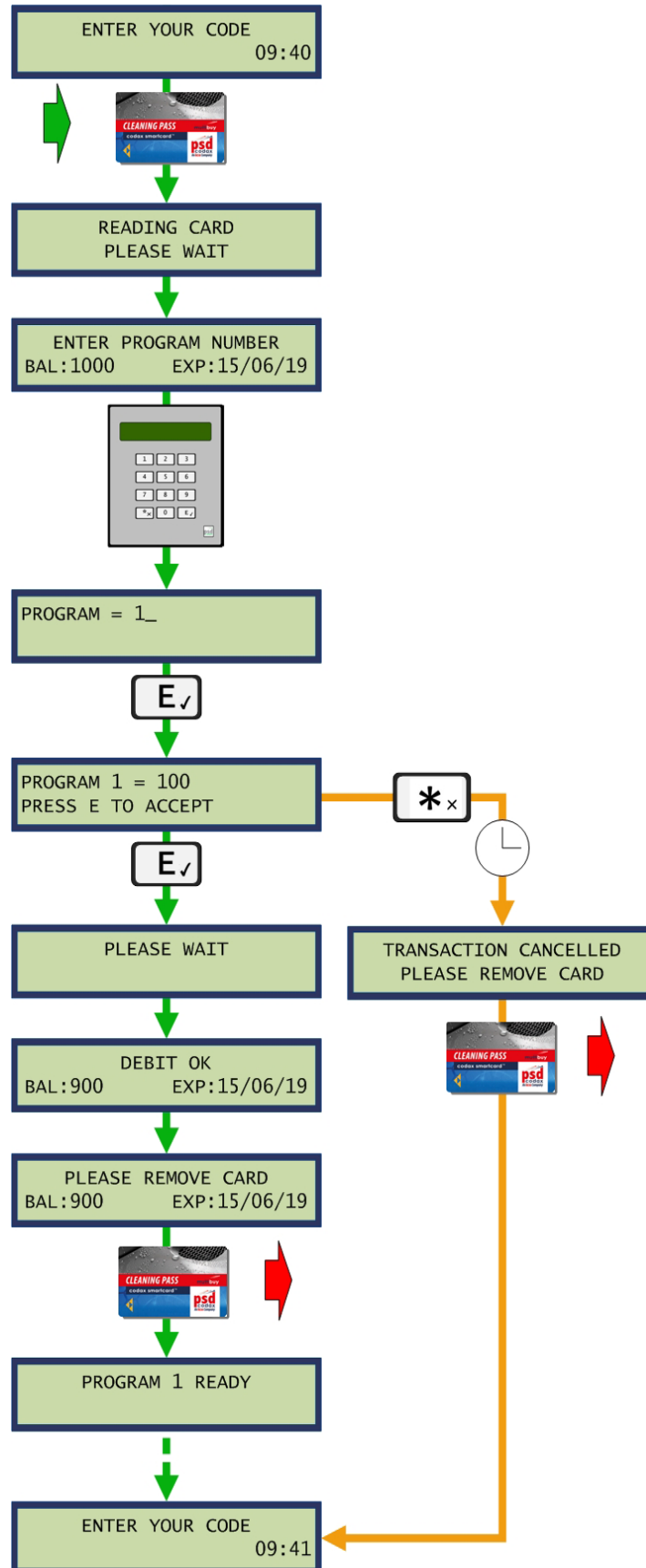

CODAX ACCESS TERMINAL OWNERS MANUAL

Program Card Transaction

For Program Card transactions the program number is fixed on the card. The Balance is shown, the expiry date of the card and the program number for which the card is valid. The transaction is confirmed on pressing the 'E' key. On completing the debit the number of washes remaining on the card is shown and on removing the card the wash is started.

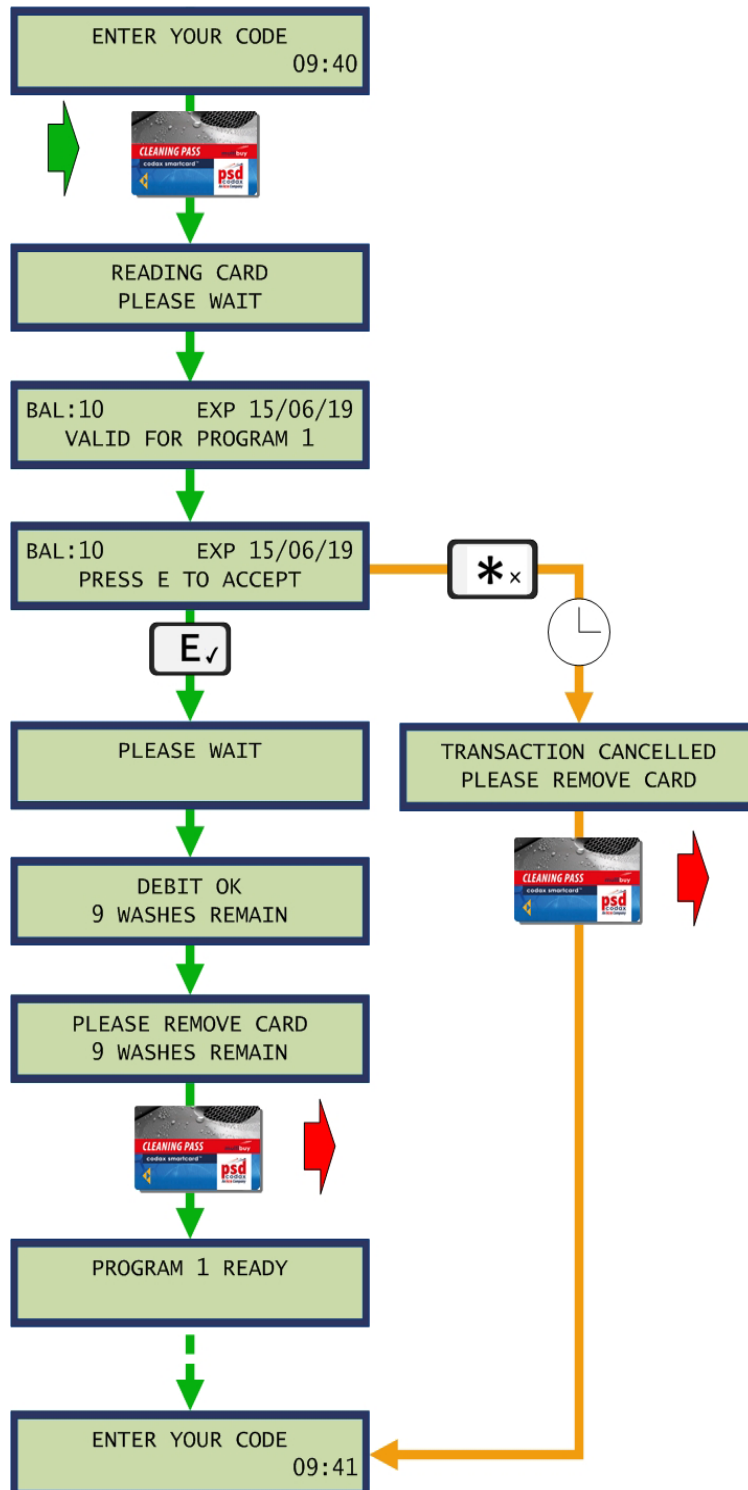

5.6.5 FAILED TRANSACTION

Read Error

On placing a card in the Smartcard reader the CAT attempts to read the card details. If this fails for any reason, the card read error message is shown. The customer should remove the card and reinsert.

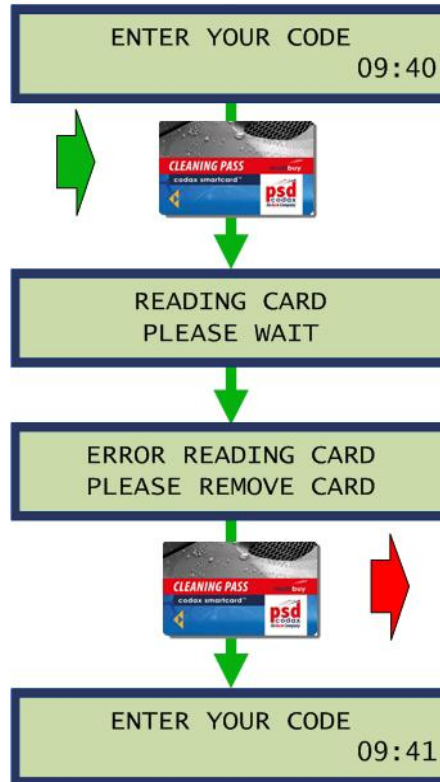

Card Removed

If the card is removed before the transaction is complete, the transaction will be cancelled

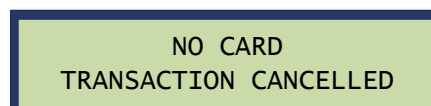

Invalid Card

A Card is deemed invalid if its Site Id is not the same as the CAT's, the card type is not supported or other discrepancy in the card details. For Program Card, this message is shown if the card is placed in the wrong machine.



CODAX ACCESS TERMINAL OWNERS MANUAL

Expired Card

If the card has expired the date that the card expired is shown before the card is removed.

Note: Any credit remaining on the card will be lost until further credit is added.



No Site Id

This message will occur if the site Id has not been set using the Admin Card. See section 5.6.3 - SMARTCARD SYSTEM MAINTENANCE.

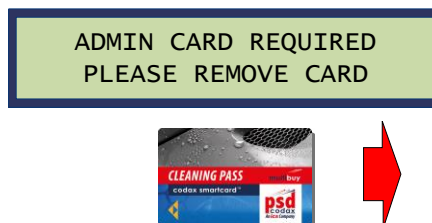

Not Enough Credit

This condition will arise if Value Card does not have enough credit for the program selected. The value of the program selected is shown along with the balance remaining on the card. The consumer is then invited to select a different program.

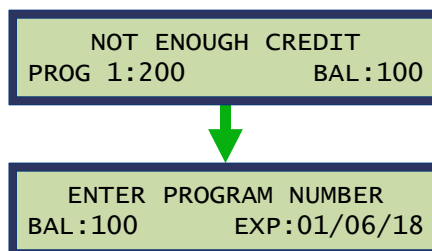

No Remaining Washes

This condition will arise if a Program Card with no remaining washes is placed in the Smartcard reader

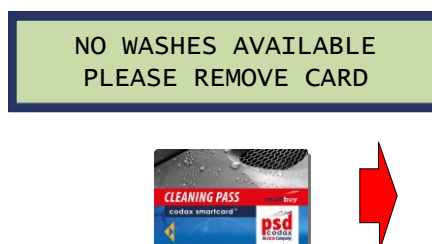

CODAX ACCESS TERMINAL OWNERS MANUAL

Service Not Available

For Value and Tracker Card, if a program is selected out of range of the machine capability the service not available message is shown. The consumer is then invited to select a different program.

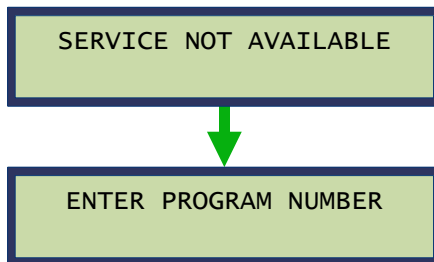

Program Blocked

The program blocked message may occur if the program blocking facility is used. Program blocking allows certain programs to be blocked if those programs are not available when operating more than one machine type. This message will occur for Value Card if a blocked program is selected and for Program Card, if the card is specific to a blocked program.

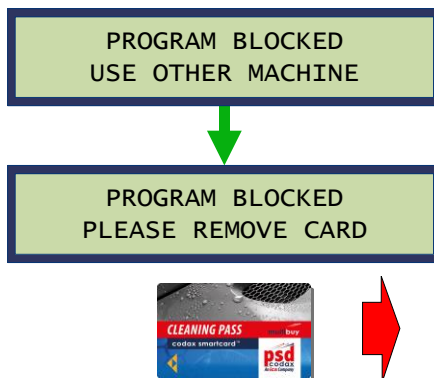

Debit Failure

If the CAT fails to debit the card for the desired service, the debit failed message is shown. The consumer should remove the card and reinsert to retry transaction

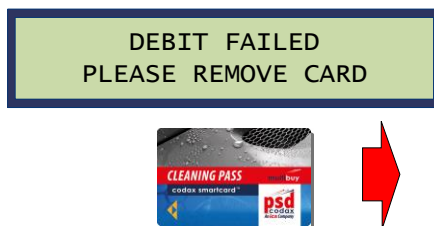

5.7 ACCESS NETWORK CONTROLLER (ANC)

The Access Network Controller (ANC) is a local network controller used to link a number of machines together. ANC is used where more than two machines are available for a single service type, such as Jet Wash, when operating a cable-less (Retro) installation. ANC is not required when operating a cabled (Ultra) installation. See section 2.4 - *INSTALLATION EXAMPLES*.

5.7.1 ANC SETUP

ANC setup uses the same system as the standard Codax Access Terminal with a setup menu available using the five-digit Engineering password as well as a number of functions available using the four-digit Access Codes. See section 3.1- *ACCESSING SYSTEM SETUP*.

5.7.2 ANC SETUP MENU

Engineering Password 32923



The Setup Menu is accessed by pressing and holding the  key for a few seconds and entering the Engineering Password. The Setup menu allows access to the following functions similar to those used in a standard Codax Access Terminal. See section 3.2. - *USER SETUP MENU*.

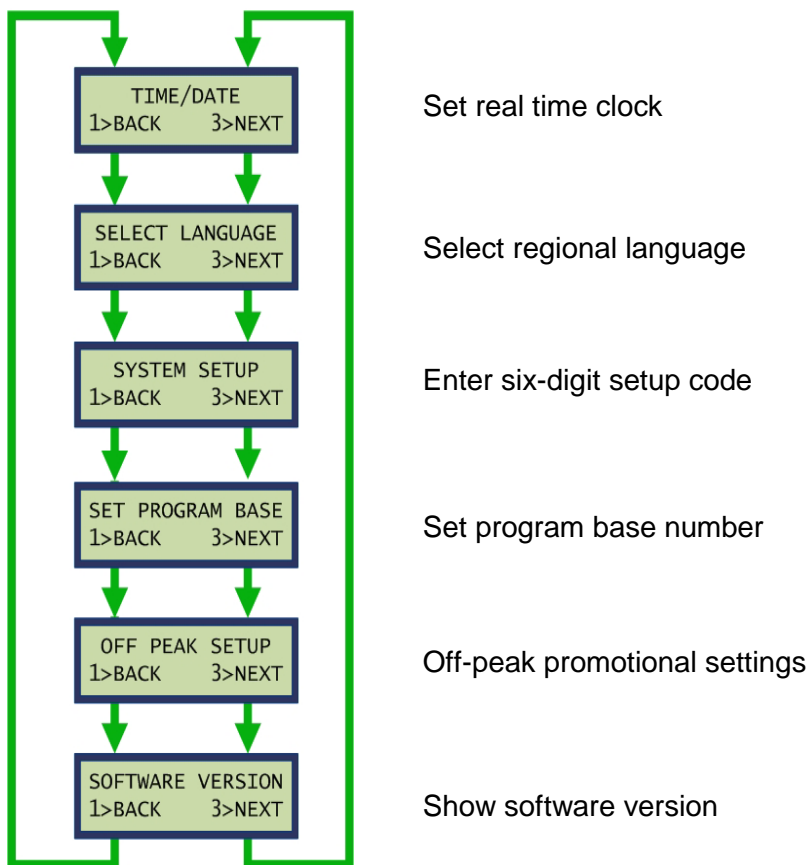

5.7.3 ANC ACCESS CODES

A number of Access Codes are also available to select individual setup functions by entering one of the unique codes listed below. Access codes are entered after pressing and holding' the



key for a few seconds. These functions are similar to those used in the standard Codax Access Terminal. See section *ACCESS CODES - 3.3*

1111 Off-peak Promotional settings

Set internal time and date setting – See *Section 3.2.8 - OFF PEAK SETUP (RETRO ONLY)*

2222 Set Time and Date

Set internal time and date setting – See *Section 3.2.2 - SET TIME AND DATE*

2223 Monitor Clock

Show current time and date setting until any key is pressed.

2360 Program Base

Set program base setting for Retro mode only – See *section 3.2.6 - SET PROGRAM BASE (RETRO ONLY)*

2364 System Setup

Enter system setup code

6723 Software Version

Show software and module version

6728 Language Selection

Allows regional language selections to be made. See *section 3.2.3 - SELECT LANGUAGE (OPTIONAL UPGRADE)*

5.7.4 OFF-PEAK IN AN ANC SYSTEM

When using Off-Peak in an ANC system, the Off-Peak settings, start time, end time and days for which Off-Peak is valid are entered at the ANC.

CODAX ACCESS TERMINAL OWNERS MANUAL

5.7.5 ANC STANDARD SYSTEM SETUP

The ANC standard system setup consists of an Access Network Controller (ANC-Primary) and up to eight Codax Access Terminals each configured as an ANC-Secondary terminals. The ANC system uses Retro Mode when Cold Start is performed at the Codax Ticket Terminal (CTT). Using the System Configuration ticket, issued by the CTT, the Setup Code and Program Base numbers are entered at the ANC-Primary terminals and all ANC-Secondary terminals connected to the Network. This is done via the Setup Menu or via the Access Codes listed above.

Note: The CAT ANC-Secondary is not a standard configuration for the CAT and is available as a factory option only.

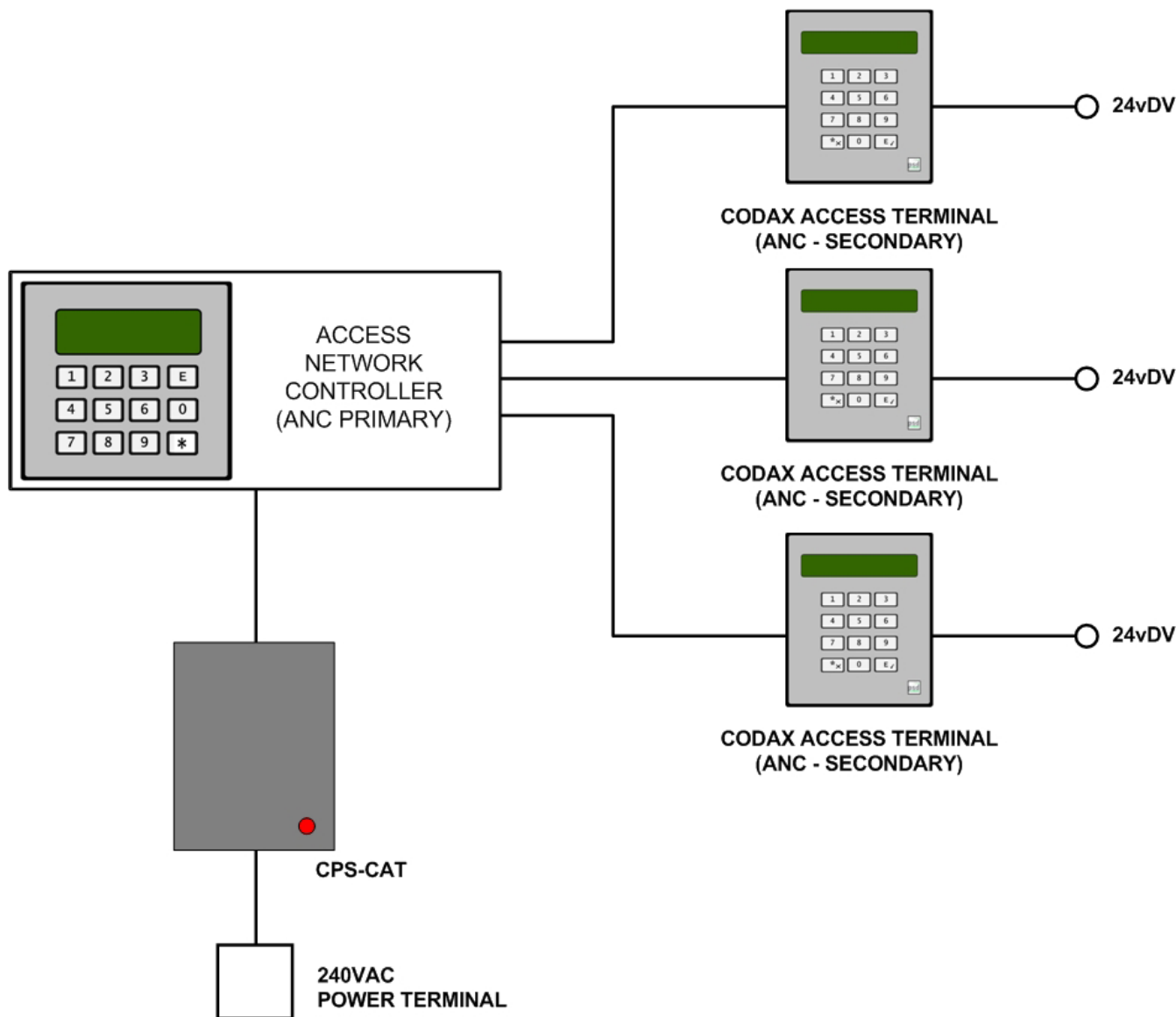

ANC Standard System Setup Example

CODAX ACCESS TERMINAL OWNERS MANUAL

5.7.6 ANC EXPANDED SYSTEM SETUP

To connect more than eight ANC-Primary Terminals to an Access Network Controller system the Expanded ANC is required (ANC-Ex). This allows up to sixteen ANC Secondary Terminals to be used. The system setup for the expanded system is as the standard system with Setup Code and Program Base numbers being entered at the ANC-Primary Terminals and all ANC-Secondary Terminals.

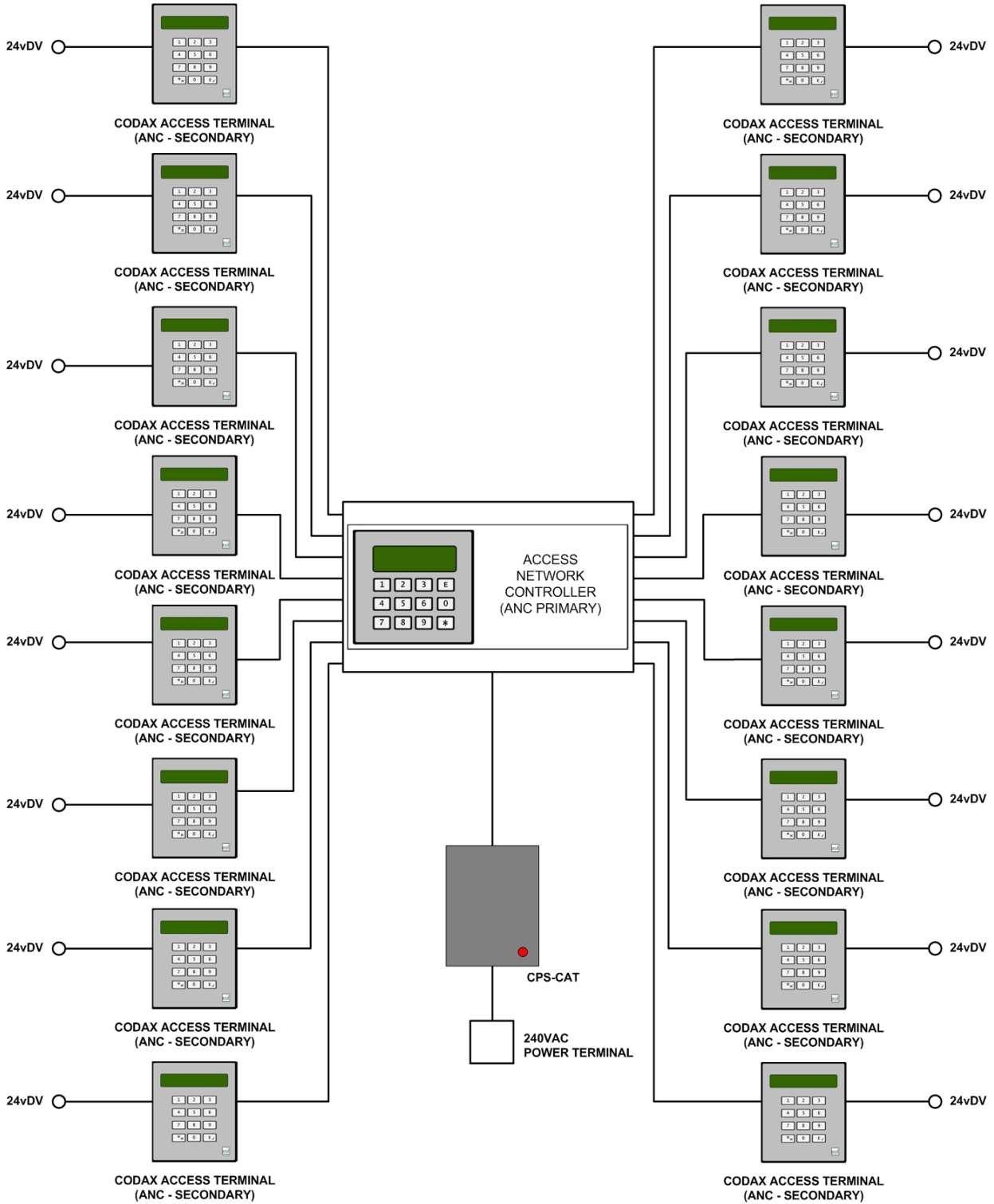

ANC Expanded System Setup Example

6 TROUBLE SHOOTING

6.1 CODAX SYSTEM FAULT CODES

6.1.1 FAULT CODE 1 – MACHINE LINK ERROR

The Machine Link refers to the cable connecting the Codax Access Terminal to the Machine. Specifically the signal wire or wires controlling the machines operation. If a problem is detected when a wash is started, the Machine Link fault is reported. The following message screens alternate at the Access Terminal until

cleared by the operator by pressing the  key.



For Ultra installation the fault is relayed back to the Ticket Terminal. The following fault message is shown on the Ticket Terminal display until cleared by the operator. A Codax System Error Report ticket is also printed. *See section 6.1.6 - CODAX SYSTEM ERROR REPORT.*

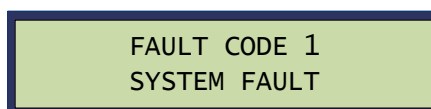

6.1.2 FAULT CODE 2 – MACHINE POWER FAILURE

This fault is reported by the Codax Access Terminal when the power indication from the Machine is lost. The following message screens alternate at the Access Terminal until the power indication is restored. The fault display automatically clears and normal operation is resumed.

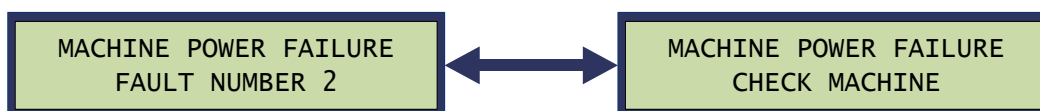

For Ultra installation the fault is relayed back to the Ticket Terminal. The following fault message is shown on the Ticket Terminal display until cleared by the operator. A Codax System Error Report ticket is also printed. *See section 6.1.6 - CODAX SYSTEM ERROR REPORT.*

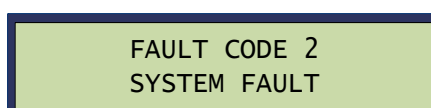

6.1.3 FAULT CODE 3 – KIOSK LINK FAILURE (ULTRA ONLY)

If a fault is detected by the Access Terminal during communication with the Ticket Terminal the Kiosk Link fault is reported. The following fault screen is shown at the Access Terminal until cleared by the operator

by pressing the  key.

CHECK KIOSK LINK
FAULT NO 3 u b

Additional information on the nature of the fault is indicated by the following letter codes:

u	No Loop Error
b	Kiosk Link Break error
p	Kiosk Link Poll error
a	Kiosk Link Acknowledge error
r	Kiosk Link Reply error
t	Kiosk Link Try's error
k	Access Code Entry (2368)

*Note: Entering Access Code **2363** at the Access Terminal will test the Kiosk Link. See Codax Access Terminal Manual for details.*

Due to the nature of this fault, no message is relayed back to Ticket Terminal.

6.1.4 FAULT CODE 4 – KEYPAD FAULT

This fault is reported by the Access Terminal when a suspected keypad fault is detected. The fault occurs when an unrecognisable code is entered a number of times at the Access Terminal. This may be due to a faulty keypad but could also be caused by random code entry in an attempt to overcome the system. The keypad fault in this instance is designed to deter such action.

KEYPAD FAULT 4

For Ultra installation the fault is relayed back to the Ticket Terminal. The following fault message is shown on the Ticket Terminal display until cleared by the operator. A Codax System Error Report ticket is also printed. *See section 6.1.6 - CODAX SYSTEM ERROR REPORT.*

FAULT CODE 4
KEYPAD FAULT

Note: This fault is automatically cleared from the Access Terminal after a few seconds

6.1.5 FAULT CODE 5 – ACCESS LINK ERROR

The access link error indicates that there is a problem with the Ultra communication link from Codax Ticket Terminal via the Codax Distribution Unit to the Access Terminal. The CDU LED indicators may indicate which channel is causing the problem.

FAULT CODE 5
ACCESS LINK ERROR

Ultra Link Fault

This is the connection from the Codax Access Terminal to the Codax Ticket Terminals via the Codax Distribution Unit. It is normally caused by a break in the communication cable. The series of CDU LED indicators will show which CAT cable is causing the problem. See *Section 6.2 - CDU LED INDICATORS*.

Secondary Terminal Link Fault

If operating using the Secondary Ticket Terminal, this fault is shown if there is a problem with the Secondary Unit, connection to the Primary Terminal or if the Secondary Terminal is disconnected.

Note: If removing the Secondary CTT from the system, it must be disabled at the Primary CTT. See CTT Operators Manual.

Note: The Secondary CTT will not operate without the Primary CTT.

6.1.6 CODAX SYSTEM ERROR REPORT

Below is an example of a Codax System Error Report printed by the Codax Ticket Terminal when a fault is reported by the Codax Access Terminal. This ticket is available for Ultra installations only.

PSD Codax
CODAX SYSTEM ERROR REPORT
Printed: 21/02/19 10:10



FAULT CODE 2
M/C LINK

6.2 CDU LED INDICATORS

6.2.1 CDU POWER INDICATION



The yellow LED is a power indicator. The normal condition of this LED is ON. The LED OFF indicates a loss of power due to a short circuit or overload. CAT and CTT power outputs from the CDU are protected by thermal fuses. An overload on these outputs will cause the fuse to overheat and shutdown.

Note: These fuses automatically recover when the fault condition clears. No user serviceable parts are fitted to this unit

-  LED On - Power ON
-  LED Off - Power OFF

6.2.2 CDU SIGNAL INDICATION

The red LED is a communication link indicator. The normal condition of this LED is off. The LED may flash on when the Ticket Terminal is communicating with an Access Terminal. A loss of communication is indicated by the LED remaining on. This fault is normally caused by a break in the cabling to the CTT or CAT.

-  LED On - Connection error
-  LED Flashing - Normal comms indication
-  LED Off - Normal operation

7 CONTACT INFORMATION

Codax™ is designed and manufactured by PSD Codax Ltd.
Bristol, England, BS14 0BY

Full Address:

PSD Codax Ltd
Axis 8
Hawkfield Business Park
Whitchurch
Bristol
BS14 0BY
England

PSD Codax website: www.psdcodax.com

For product information, pricing or to place an order:

Email: sales@psdcodax.com

Call: +44 (0) 1275 866910.

For technical support:

Email: service@psdcodax.com

Call: +44 (0) 1275 866910.

Notices

PSD Codax Limited operate a continued product and component development programme. We reserve the right to modify/change as necessary. All technical specifications, Codax system software and information documents produced by PSD are copyright protected. Written permission is required from a Director of the company prior to any reproduction.

We may send you software by electronic mail, you are only authorised to make one copy of this software image onto an EPROM/Software module after which the software image must be deleted from your computer. Any development software sent electronically to you for the purpose of testing and development is for this purpose only and any reproduction or operational use of the software is not permitted and will be in breach of our copyright and trading terms.

PSD Codax Limited is registered in England at Axis 8, Hawkfield Business Park, Whitchurch, Bristol. BS14 0BY. Company number 04204089.

Our standard terms and conditions of trading and payment will apply to all transactions. Please request current issue.



To learn more about PSD Codax,
our services and our products,
please contact us.

t: +44 (0) 1275 866 910
w: www.psdcodax.com
e: info@psdcodax.com

Defining the World of Car Wash Technology

Smartstart Plus | Smartstart Pro | Auto Sentry® Petro | Auto Sentry® Flex | Auto Sentry® CPT | WashConnect®

